



## KRC

### Rigid Rogowski coil

- High linearity from 0.1A to 150kA
- Wide dynamic range
- Very useful for large size or awkward shaped conductors or in places with limited access
- No danger from open-circuited secondary
- Not damaged by large overloads
- Non-intrusive, no power drawn from the main
- Measurement uniformity at any position of the conductor inside the coil
- Excellent degree of rejection to the external current conductor

#### Feature

The KRC current transformers are suited for installation in industrial environments on insulated cables or bushing insulators. Thanks to the possibility of disconnection, they can be applied to existing installations without having to dismantle those. They are used for measurements, energy quality analysis and protection in low-, medium- and high-voltage power networks with frequencies of 50 or 60 Hz. The transformers are made in PCB (Printed Circuit Board) technology. As a result, very high precision of the transformer's geometry has been obtained and, consequently, high repeatability of electrical parameters. They are characterized by a constant conversion rate (sensitivity) over the entire measurement range.

KRC current transformers developed at ITR work on the principle of Rogowski coil. The conversion factor  $S$  is defined as the ratio of the RMS voltage value at the transformer output to the RMS value of the sinusoidal current at 50 Hz (60 Hz) flowing in the transformer's primary circuit. The conversion ratio in a 60 Hz network is 1.2 times greater than in a 50 Hz network. This results from the fact that the voltage at the transformer output is proportional to the current derivative in the primary circuit. Thanks to their very good electrical parameters, low weight and small size, the transformers replace classic core transformers.

## What is a Rogowski coil?

Rogowski coils have been used for the detection and measurement of electric currents for decades. They are based on a simple principle: an “air-cored” coil is placed around the conductor in a toroidal fashion and the magnetic field produced by the current induces a voltage in the coil. The voltage output is proportional to the rate of change of current. This voltage is integrated, thus producing an output proportional to the current.

By using precision winding techniques, especially developed for the purpose, the coils are manufactured so that their output is not influenced by the position of the conductor within the toroid, and to reject interference from external magnetic fields caused, for example, from nearby conductors. Basically, a Rogowski coil current measuring system consists of a combination of coil and conditioning electronics. Rogowski coil current transducers are used for the AC measurement.

They can be used in similar circumstances to current transformers, but for many applications they have considerable advantages:

- Wide dynamic range.
- High linearity.
- Very useful with large size or awkward shaped conductors or in places with limited access. Thanks to the structure without hard core, the coil can be easily manufactured according to the application or to the available space.
- Unlike traditional current transducers, there is no danger from open-circuited secondaries.
- They cannot be damaged by large overloads.
- They are non-intrusive. They draw no power from the main circuit carrying the current to be measured.
- They are also light weighted and in some applications are light enough to be suspended on the conductor being measured.

The transducer does not measure direct currents but, unlike a current transformer, it can carry out accurate measurements of AC component even if there is a large superimposed DC component, since there is no iron core causing saturation. This feature is particularly useful for measuring ripple currents for example in battery charging systems.

## Installation method

---

The transformer connection should be made with a shielded twisted-pair cable. The twisted pair shield should be connected to the PE only from the side of the measuring or protection device (field controller). The sequence of wires (S1, S2) in the twisted pair between the transformer connector and the field controller connector should be the same for all transformers, as shown in the picture

## Housing

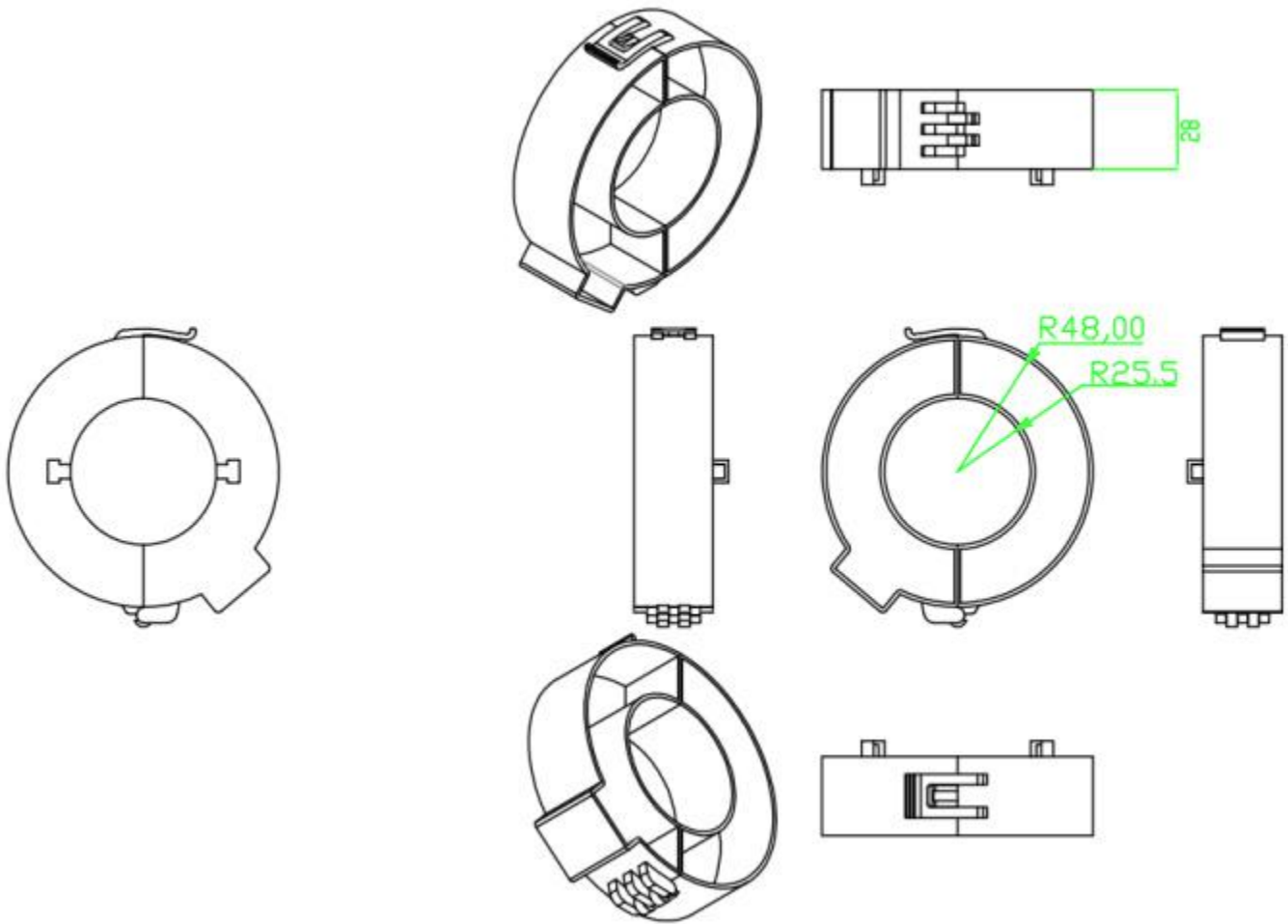

## Specification

Input/output circuit	
Maximum continuous voltage at the device terminals	~24 V
Maximum temporary voltage at the device terminals	~150 V
Maximum unique voltage at the device terminals	250 V
Test voltage of electrical strength	~2 kV
Rated frequency	50 / 60 Hz
Work frequencies	1 Hz ... 20 kHz
Accuracy class	0.5
<i>The transformer's operating conditions (current, conversion factor) should be selected so that the transformer's output voltage does not exceed the safe voltage of ~ 24 V during normal operation</i>	

Environmental conditions	
Working temperature	-40°C ... +85°C
Storage temperature	-55°C ... +90°C
Air humidity	no water vapor condensation and frost deposition
Insulation class after installation	1
Installation category	III
Class of industrial environment	B
Degree of contamination	2

Protection rating		
Degree of housing protection	IP 68	
Degree of protection - screw joint	IP 00	
Degree of protection - 2 IN 1 clamp joint	IP 40	
Degree of protection - SR joint	IP 40	
Connectors		
Cable type	shielded twisted pair Ø5	
Mechanical resistance		
Testing strength and resistance to sinusoidal vibrations	PN-EN 60255-21-1:1999	Class 1
Testing strength and resistance to single and multiple impacts	PN-EN 60255-21-2:2000	Class
Weight and dimensions		
Inner diameter [ mm ]	51	
Outer diameter [ mm ]	96	
Thickness [mm]	28	
Weight [ g ]	249	

Parameter	Unit	Conditions	type
<b>S</b> (Conversion rate)	[mV/A]	50 Hz	1.025
		60 Hz	1.23
Measurement range	[A]	min.	0.1
	[kA]	max.	150
<b>ID</b>	[kA]	< 1 h	24
<b>Ith (1 s)</b>	[kA]	≤1 s	150
<b>Rc</b> (transformer resistance)	[ Ω ]	-40 °C	660
		25 °C	880
		85 °C	1080
<b>Ro</b> (load resistance)	[ kΩ ]	min.	≥ 30

**Characteristics:**

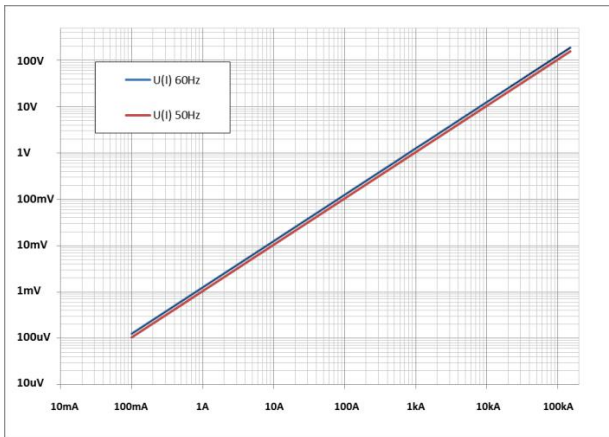

Characteristic of the  $U$  output voltage dependence on the current  $I$

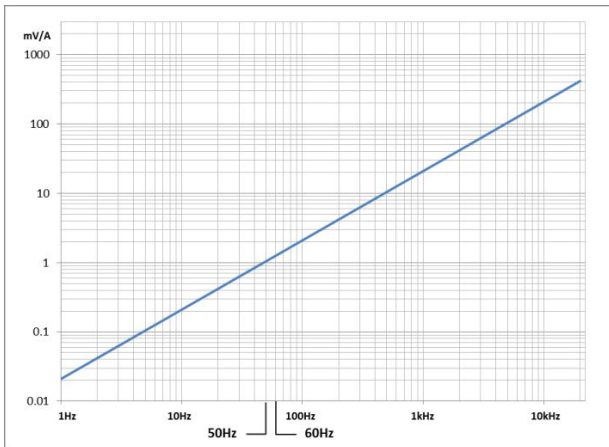

Characteristic of the dependence of the conversion rate  $S$  (sensitivity) on the frequency  $f$  of the current

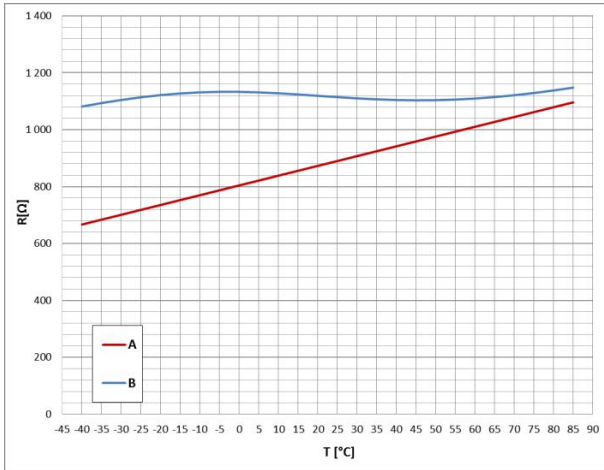

Characteristics of dependence of resistance on temperature (A – X1, B – X2)

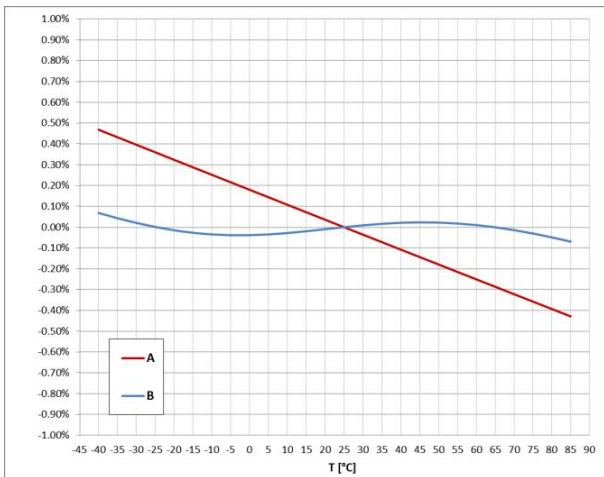

Characteristic of the dependence of the measurement error on temperature for  $R_0=47k\Omega$  (A – X1, B – X2)

## Safety and warning notes

---

In order to guarantee safe operation of the transducer and to be able to make proper use of all features and functions, please read these instructions thoroughly! Safe operation can only be guaranteed if the transducer is used for purpose it has been designed for and within the limits of the technical specifications. Ensure you get up-to-date technical information, it can be found in the latest associated datasheet under [www.rogowski.cn](http://www.rogowski.cn)

### **Caution! Risk of danger**

Ignoring the warnings can lead to serious injury and/or cause damage!

The electric measuring transducer may only be installed and put into operation by qualified personnel that have received an appropriate training, The corresponding national regulations shall be observed during installation and operation of the transducer and any electrical conductor. The transducer shall be used in electric/electronic equipment the respect to applicable standards and safety requirements and in accordance with all the related systems and components manufacturers' operating instructions.

### **Caution! Risk of electrical shock**

When operating the transducer, certain parts of the module may carry hazardous live voltage (e.g, primary conductor). The user shall ensure to take all measures necessary to protect against electrical shock. The transducer is a build-in device containing conducting parts that shall not be accessible after installation. A protective enclosure or additional insulation barrier is necessary. Avoid using transducer in rainy or humidity high voltage circumstances. Installation and maintenance shall be done with the main power supply disconnected except if there are no hazardous live parts in or in close proximity to the system and if the applicable national regulations are fully observed.

Safe and trouble-free operation of this transducer can only be guaranteed if transport, storage and installation are carried out correctly and operation and maintenance are carried out with care.

### **WARNING!**

Do not stress the coil by applying any kind of mechanical force (e.g, twisting, puncturing, excessive pressure, tight bending, etc.) which will dramatically degrade the device's accuracy.

In high voltage circumstances, any operation is extremely dangerous! We do not take responsible for any danger or personal safety that is caused by any improper operation, damaged device or aging products. We are only responsible for the product itself.



## Order code

### Coil:

Coil Model	Coil diameter (mm)	Output ratio and tolerance	Signal cable length
Code: Y-FCT	Code:200(Typical rated 500A)	Code:110 110mV/kA@50Hz±5%	
	Code:350(Typical rated 1500A)	Code:100 100mV/kA@50Hz±0.5%	
Code: NRC	Code:510(Typical rated 3kA)	Code:85 85mV/kA@50Hz±0.5%	
	Code:800(Typical rated 10kA)	Code:50 50mV/kA@50Hz±0.5%	
Y-FCT code is length.			
Code: MRC	Code:100(Typical rated 1kA)	Code:60 60mV/kA@50Hz±5%	Code: -2m
	Code:150(Typical rated 3kA)	Code:50 50mV/kA@50Hz±0.5%	Code: -5m
	Code:200(Typical rated 6kA)	Code:50 50mV/kA@50Hz±0.5%	Code: -10m
Code: D-SRC	Code:16(Typical rated 100A)	Code:60 60mV/kA@50Hz±5%	Code: -20m
	Code:24(Typical rated 300A)	Code:50 50mV/kA@50Hz±0.5%	
	Code:36(Typical rated 600A)	Code:360 360mV/kA@50Hz±5%	
	Code:50	Code:333 333mV/kA@50Hz±0.5%	
	Code:100	Code:100 100mV/kA@50Hz±0.5%	
	Code:150	Code:85 85mV/kA@50Hz±0.5%	
Other requirements could be OEM			

**Final Code=Coil model + Coil length (MRC NRC is diameter) + Output ratio tolerance + Signal cable length**

For example:

Y-FCT-350-100-2m is Y shape connector, coil length 350mm, output 100mV/kA@50Hz 0.5% tolerance, signal cable length is 2meter.