



ME337

Three phase multi-function smart meter

Manual-V1.1.230626

ROGOWSKI TECHNOLOGY (SHANGHAI) CO., LTD.

Contents

1. Product Features	1
2. Product operation process	1
3. Product Description.....	2
3.1 Dimensions.....	2
3.2 Model Naming Conventions	2
3.3 Feature Overview	2
4. Data display	4
5. Accuracy and certification	5
6. Wiring.....	6
6.1 Power supply.....	8
6.2 Wiring type	8
6.3 RS485	11
6.4 Relay output	11
6.5 Digital input.....	11
6.6 Energy pulse output.....	12
7. Functionality	12
7.1 Current transformer type support	12
7.2 Current transformer orientation setting	12
7.3 Current transformer channel settings	12
7.4 Multi-Tariff.....	12
7.4.1 Manual Control Mode	13
7.4.2 RTC Control Mode.....	13
7.5 Demand.....	13
7.5.1 Demand Calculation Method.....	13
7.6 Alarm	14
7.6.1 Alarm output.....	15
7.7 Phase sequence detection	15
8. Interface display and operation	15
8.1 Display interface and buttons	15
8.2 Meter start-up interface	18
8.3 Meter display mode switching	18
8.4 Real-time measurement data interface.....	19
8.4.1 Real-time measurement data interface 3P4W	19
8.4.2 Real-time measurement data interface 3P3W	20
8.4.3 Real-time measurement data interface 1P3W	21
8.4.4 Real-time measurement data interface 1P2W	23
8.5 Power quality interface	23
8.5.1 Power quality interface 3P4W.....	24
8.5.2 Power quality interface 3P3W.....	27
8.5.3 Power quality interface 1P3W.....	28
8.5.4 Power quality interface 1P2W.....	31
8.6 Voltage Harmonic Interface	33
8.6.1 Voltage harmonic interface 3P4W.....	33
8.6.2 Voltage harmonic interface 3P3W.....	34
8.6.3 Voltage harmonic interface 1P3W.....	34
8.6.4 Voltage harmonic interface 1P2W.....	35
8.7 Current Harmonic Interface	35
8.7.1 Current Harmonic Interface 3P4W	35
8.7.2 Current Harmonic Interface 3P3W	36
8.7.3 Current Harmonic Interface 1P3W	36
8.7.4 Current Harmonic Interface 1P2W	37
8.8 Energy Data Interface.....	37
8.8.1 Energy Data Interface 3P4W	38
8.8.2 Energy Data Interface 3P3W	40
8.8.3 Energy Data Interface 1P3W	41

8.8.4 Energy Data Interface 1P2W	42
8.9 Device Information Interface	43
8.10 Device Configuration Interface	44
8.10.1 Configuration parameter selection	44
8.10.2 Configure grid parameters	45
8.10.3 Configuring Current Transformer Parameters	48
8.10.4 Configuring Zero Drift Suppression Parameters	52
8.10.5 Configure Tariff parameters	53
8.10.6 Configure Demand Parameters	54
8.10.7 Configuring Communication Parameters	54
8.10.8 Configure relay parameters	57
8.10.9 Configuring device parameters	57
8.10.10 Configure the clear parameter	60
9. Modbus Communication	60
9.1 Modbus Communication settings	61
9.2 Modbus-RTU data frame	61
9.3 PDU Request data Format	61
9.4 Function code	61
9.5 Register Description	62
9.6 Data type list	62
9.7 Configuration results	63
9.8 Modbus-RTU Function code	63
9.8.1 Function code (0x10=16) Operation Instructions	63
9.8.2 Function code (0x03=3) operation instructions	65
9.8.3 Error response	66
9.9 List of configuration instructions	67
9.9.1 System parameter setting	67
9.9.2 Parameter setting of L1,L2,L3 current transformer	67
9.9.3 Parameter setting of N-phase current transformer	68
9.9.4 Current Sensor Direction setting	68
9.9.5 Current Sensor Channel setting	68
9.9.6 Zero drift suppression setting	69
9.9.7 Demand parameter setting	69
9.9.8 Tariff mode setting	70
9.9.9 Manual tariff setting	70
9.9.10 RTC tariff period setting	70
9.9.11 RTC tariff select setting	70
9.9.12 Device time setting	71
9.9.13 Communication parameter setting	71
9.9.14 Reset setting	72
9.9.15 Relay output control mode	72
9.9.16 Relay output manual control	72
9.9.17 Alarm setting	72
9.10 Register list	73
9.11 Modbus Register list	74
9.11.1 Equipment parameters	74
9.11.2 Communication parameter	74
9.11.3 Relay	75
9.11.4 Digital input	75
9.11.5 Voltage and current phase sequence	75
9.11.6 Configure instruction register	76
9.11.7 Power system	76
9.11.8 Current Sensor Direction	78
9.11.9 Current Sensor Channel	78
9.11.10 Zero drift suppression parameter	79

9.11.11 Tariff parameter	79
9.11.12 Voltage, current, power, power factor	80
9.11.13 Energy.....	81
9.11.14 Tariff Energy	83
9.11.15 Demand register	83
9.11.16 Voltage and current harmonic register	86
9.11.17 Max.&Min.	88
9.11.18 Unbalance degree.....	90
9.11.19 Current K-factor and crest factor register	90
9.11.20 Voltage and current angle register	91
9.11.21 Alarm.....	91
10. Revision History	98

1. Product Features

- Fast installation
 - Product size is standard 96 panel type
 - Installation method is a snap on type, without screws
- Support multiple current transformer connections
 - The ME337N series supports a new type of current transformer – rogowski coil direct connection, without the need for an external integrator
 - The ME337N series supports voltage output type current transformer connection simultaneously
 - The ME337C series supports direct current connection, with a maximum connection current of 7A
- Support multiple power grid systems
 - Supports three-phase four wire, three-phase three wire, one phase three phase, and single-phase systems
- Multiple power supply options available
 - Available in 220VAC, 24VDC and 12VDC power supplies
- Support voltage and current harmonic measurement
 - Supports voltage, current, fractional harmonics, up to 50 measurements
 - Support voltage and current harmonic distortion and harmonic value measurement
 - Support voltage and current total harmonic distortion measurement
- More features
 - Support 6 rate tariff energy, support RTC switching or manual switching
 - Support demand measurement
 - Support alarm setting
 - Support current transformer orientation modification
 - Support current channel modification

2. Product operation process

- 1) Determine the type of grid system to be measured and wire it according to the corresponding wiring diagram, see 6.2
- 2) Confirm the type and scope of power supply of the product, and power up the product
- 3) Modify the meter wiring method parameter to the type of grid system to be measured, see 8.10.2.1
- 4) Modify the meter nominal frequency parameter to the nominal frequency of the grid to be measured, see 8.10.2.2
- 5) Modify the PT ratio of the meter according to whether a voltage transformer is used, see 8.10.2.4
- 6) Modify the meter current conversion coefficient, according to whether the current conversion coefficient needs to be configured, see 8.10.2.5
- 7) Modify the meter current transformer type parameters, depending on the type of current sensor used, see 8.10.3.1

- 8) Modify the current transformer ratio parameters corresponding to the meter, according to the current transformer ratio used, see 8.10.3.2
- 9) Modify the nominal current parameters corresponding to the meter, according to the maximum current to be measured, see 8.10.3.3
- 10) Modify the zero-drift suppression parameters according to the minimum voltage and current to be measured, see 8.10.4
- 11) Verify whether the voltage, current, and power are correct (if not, there is a problem with the wiring or configuration)

3. Product Description

3.1 Dimensions



figure 3-1 Meter dimension

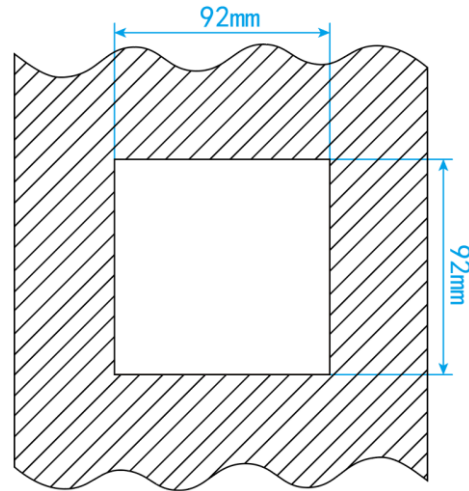
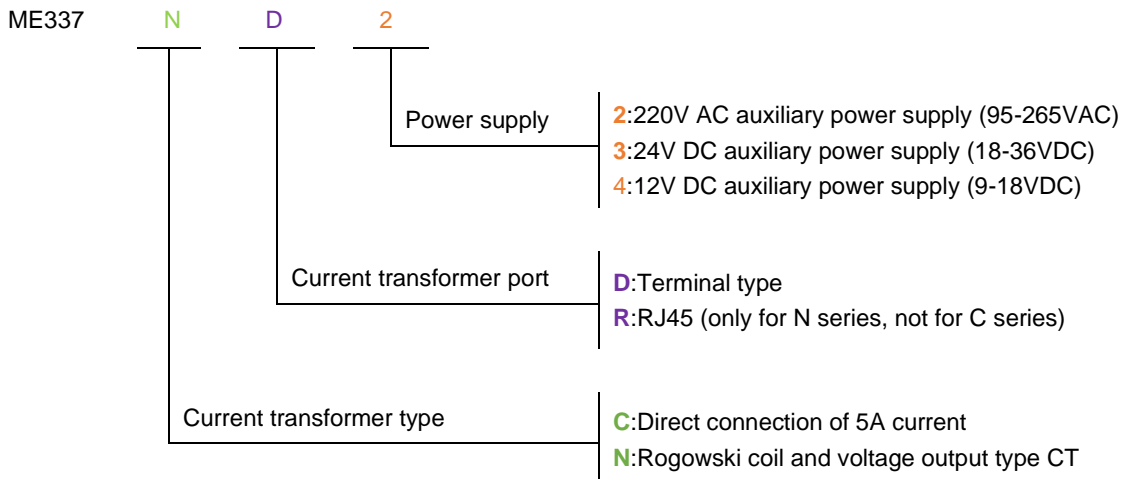

figure 3-2 Installation

3.2 Model Naming Conventions



3.3 Feature Overview

ME337 panel type three-phase multi-function power meter, external open Rogowski coil or voltage type CT, realize the test without removing the wire, simplify the test steps, and save construction costs. ME337 supports three-phase four-wire, three-phase three-wire, one-phase three-wire and single-phase

systems; It can measure multiple electrical parameters such as voltage, current, power factor, harmonics, power, and energy of A, B and C phases.

ME337 is equipped with RS485 communication interface, through the standard Modbus-RTU protocol, can be compatible with various configuration systems, the front-end collected electrical parameters real-time transmission to the system data center.

overview			
Type	Panel type		
Model	ME337		
Current sensor type	ME337N	ME337C	
	Rogowski coil, voltage output type CT		Current type transformer
Characteristic	Support direct access to Rogowski coils	Direct current connection	
Advantage	Suitable for wide current range, without disassembling wires for measurement		
Wire system	3P4W 4CT,3P4W 3CT,3P3W 3CT,3P3W 2CT,1P3W,1P2W		
Application	Power analysis, energy measurement		
Display screen	LCD display		
Weight	259g		
Size	L*W*D:96*96 *45mm		
Color	White and black		
Current measurement			
Channel input range	ME337N	ME337C	
	0-900mVAC peak,636mV RMS		0-7A AC
Measuring range	Rogowski coils	Voltage output type CT	0-7A AC
	50mV/kA@50Hz(0-12000A),@60Hz(0-10000A) 85mV/kA@50Hz(0-7000A),@60Hz(0-6000A) 100mV/kA@50Hz(0-6000A),@60Hz(0-5000A)...	Varies with instrument transformer parameters	
Voltage measurement			
Measuring range	0~600VAC Phase voltage		
Maximum measurement	720VAC Phase voltage		
Digital signal			
Relay output	1 electromagnetic relay output, contact capacity: 3A 30V DC, 3A 250V AC		
Digital input	2 dry contact inputs, optocoupler isolated (5kVrms)		
Communication			
RS485	One RS485 communication interface, interface type: two-wire half-duplex Communication rate: 2400bps~115200bps Specification: Modbus-RTU		
Power supply			
Power	ME337XX2	ME337XX3	ME337XX4
	95~265VAC/110~370VDC,45~60Hz		18-36VDC
Maximum power consumption	3.5VA		

4. Data display

Instantaneous value	
Phase voltage	U1,U2,U3,AVG
Line voltage	U12,U23,U31,AVG
Current	I1,I2,I3,AVG,In
Grid frequency	F1,F2,F3,Σ (Total)
Power factor PF	PF1,PF2,PF3,Σ(Total)
Displacement Power factor DPF	DPF1,DPF2,DPF3,Σ(Total)
Active power	P1,P2,P3,Σ(Total)
Reactive power	Q1,Q2,Q3,Σ(Total)
Apparent power	S1,S2,S3,Σ(Total)
Energy	
Active Energy Import	EP1,EP2,EP3,Σ(Total) When the total Energy reaches 1.0 x 10 ⁹ kWh, the energy of each phase will automatically clear to zero
Active Energy Export	EP1,EP2,EP3,Σ(Total) When the total Energy reaches 1.0 x 10 ⁹ kWh, the energy of each phase will automatically clear to zero
Reactive Energy Import	EQ1,EQ2,EQ3,Σ(Total) When the total Energy reaches 1.0 x 10 ⁹ kVARh, the energy of each phase will automatically clear to zero
Reactive Energy Export	EQ1,EQ2,EQ3,Σ(Total) When the total Energy reaches 1.0 x 10 ⁹ kVARh, the energy of each phase will automatically clear to zero
Apparent Energy	ES1,ES2,ES3,Σ(Total) When the total Energy reaches 1.0 x 10 ⁹ kVAh, the energy of each phase will automatically clear to zero
Tariff Energy	ET1,ET2, ET3,ET4, ET5,ET6 When Energy reaches 1.0 x 10 ⁹ kWh, Energy automatically clears to zero
Harmonics	
Voltage harmonic percentage	Total harmonics (U1, U2, U3), odd total harmonics (U1, U2, U3), even total harmonics (U1, U2, U3) Fractional harmonics of order 1-50 (U1, U2, U3)
Current harmonic percentage	Total harmonics (I1, I2, I3), odd total harmonics (I1, I2, I3), even total harmonics (I1, I2, I3), K factor (I1, I2, I3) Fractional harmonics of order 1-50 (I1, I2, I3)
Voltage harmonic value	Total harmonics (U1, U2, U3) Fractional harmonics of order 1-50 (U1, U2, U3)
Current harmonic value	Total harmonics (U1, U2, U3) Fractional harmonics of order 1-50 (U1, U2, U3)
Phase diagram	
Phase sequence	Voltage, current
Voltage angle	U1,U2,U3

Current angle	I1,I2,I3
Voltage and current angle	UI1,UI2,UI3
Demand	
Demand	Total Active power, Total Reactive power, Total Apparent power
Total Active power demand max	Maximum demand and time
Total Reactive power demand max	Maximum demand and time
Total Apparent power demand max	Maximum demand and time
Unbalance	
Voltage unbalance	Negative order, zero order
Current unbalance	Negative order, zero order
Max. & Min.	
Phase voltage	Phases and averages
Line voltage	Phases and averages
Current	Phases and averages
Active power	Phases and averages
Reactive power	Phases and averages
Apparent power	Phases and averages

5. Accuracy and certification

Measuring accuracy	
current measurement accuracy	0.1%+Accuracy of current sensor
Voltage measurement accuracy	$\pm 0.2\%$ (60V~600V AC)
Grid frequency	$\pm 0.01\%$ (45~65Hz)
Power factor	± 0.005
Active and apparent power	IEC62053-22 level 0.5S
Reactive power	IEC62053-21 level 1S
Active energy	IEC62053-22 level 0.5S
Reactive energy	IEC62053-21 level 1S
Environment condition	
Operating temperature	-20℃~+70℃
Storage temperature	-40℃~+85℃
Humidity range	5~95% RH, 50℃(non-condensing)
Class of pollution	2

Over voltage capability	CAT III 1000V, It is suitable for distribution system below 277 / 480VAC
Insulation strength	IEC61010-1
Altitude	3000m Max
Antipollution level	IP20(Meet the standard of IEC 60629)
Quality guarantee period	12 months
EMC (electromagnetic compatibility)	
Electrostatic discharge	Level IV(IEC61000-4-2)
Radiated immunity	Level III (IEC61000-4-3)
EFT Electrical fast burst immunity	Level IV (IEC61000-4-4)
Surge immunity	Level IV (IEC61000-4-5)
Conducted disturbance immunity	Level III (IEC61000-4-6)
Power frequency magnetic field immunity	0.5mT (IEC61000-4-8)
Conduction and radiation	Class B (EN55022)
Measurement standard	
EN 62052-11, EN61557-12, EN 62053-21, EN 62053-22, EN 62053-23, EN 50470-1, EN 50470-3, EN 61010-1, EN 61010-2, EN 61010-031	

6. Wiring

The meter is equipped with a wide range of interfaces to realize different functions.

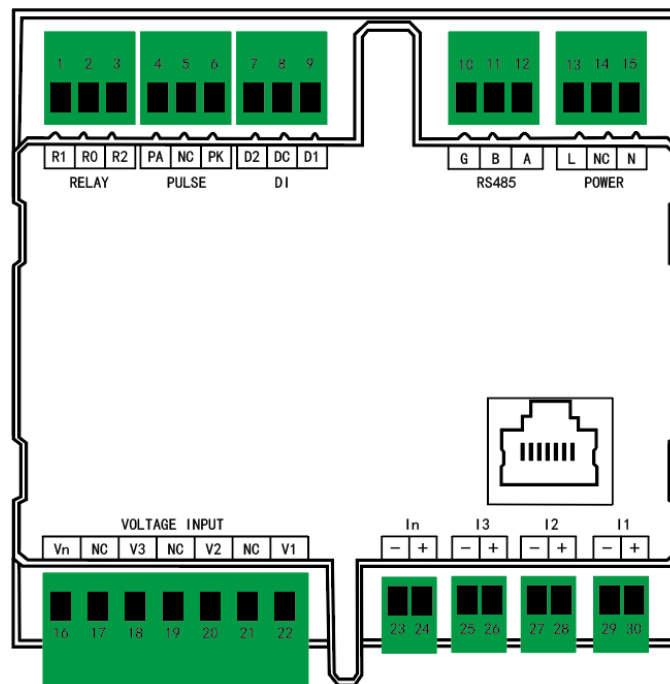

figure 6-1 Interface

No.	Name	Definition	Type	Remarks
1	R1	Relay normally open contacts	Relay output	It is a relay output with normally open and normally closed contacts
2	R0	Relay common contacts		
3	R2	Relay normally closed contacts		
4	PA	Pulse output positive terminal	Pulse output	Active Energy pulse output
5	NC	Empty terminal		
6	PK	Pulse output negative terminal		
7	D2	Digital input channel 2	Digital input	The two channels are dry contact inputs
8	DC	Digital channel common end		
9	D1	Digital input channel 1		
10	G	RS485 GND	RS485	RS485 Communication
11	B	RS485 B		
12	A	RS485 A		
13	L	Power supply (+)	Power supply	Power supply
14	NC	Empty terminal		
15	N	Power supply (-)		
16	Vn	N-phase voltage input	Voltage input	Voltage input channel
17	NC	Empty terminal		
18	V3	C-phase voltage input		
19	NC	Empty terminal		
20	V2	B-phase voltage input		
21	NC	Empty terminal		
22	V1	A-phase voltage input		
23	I _{n-}	N-phase current input negative	Current input	ME337XD series current channel
24	I _{n+}	N-phase current input positive		
25	I ₃₋	C-phase current input negative		
26	I ₃₊	C-phase current input positive		
27	I ₂₋	B-phase current input negative		
28	I ₂₊	B-phase current input positive		
29	I ₁₋	A-phase current input negative		
30	I ₁₊	A-phase current input		

		positive		
31	RJ45	ABC three-phase current input	Current input	ME337XR series current channel

6. 1 Power supply

The meter adopts external power supply mode, and there is no internal direct power supply.

- **Do not connect the meter while the cable is live**
- **Before connecting the power supply, it is necessary to confirm whether the power supply voltage is within the required range, otherwise the meter cannot work properly**

6. 2 Wiring type

Meter support wiring type, three-phase four-wire 4CT (3P4W_4CT), three-phase four-wire 3CT (3P4W_3CT), three-phase three-wire 3CT (3P3W_3CT), three-phase three-wire 2CT (3P3W_2CT), one-phase three-wire (1P3W), one-phase two-wire (1P2W)

- **The actual wiring type of the meter must be consistent with the wiring method of the internal configuration of the meter**
- **Three-phase four-wire 4CT (3P4W_4CT) requires 4 current sensors, and the N-phase current is measured through the sensor**
- **Three-phase four-wire 3CT (3P4W_3CT) requires 3 current sensors, and the N-phase current is calculated by calculation**
- **Three-phase three-wire 3CT (3P3W_3CT) requires 3 current sensors, and the B-phase current is measured through the sensor**
- **Three-phase three-wire 2CT (3P3W_2CT) requires 2 current sensors, and the B phase current is calculated by calculation**
- **The phase sequence of voltage and current must be in accordance with the phase sequence of ABC, otherwise the meter will show that the voltage and current phase sequence is wrong**
- **When using a current sensor, pay attention to the current arrow pointing on the sensor must be consistent with the actual current flow direction, that is, the sensor current arrow points to the load end**

The voltage and current wiring type is as follows:

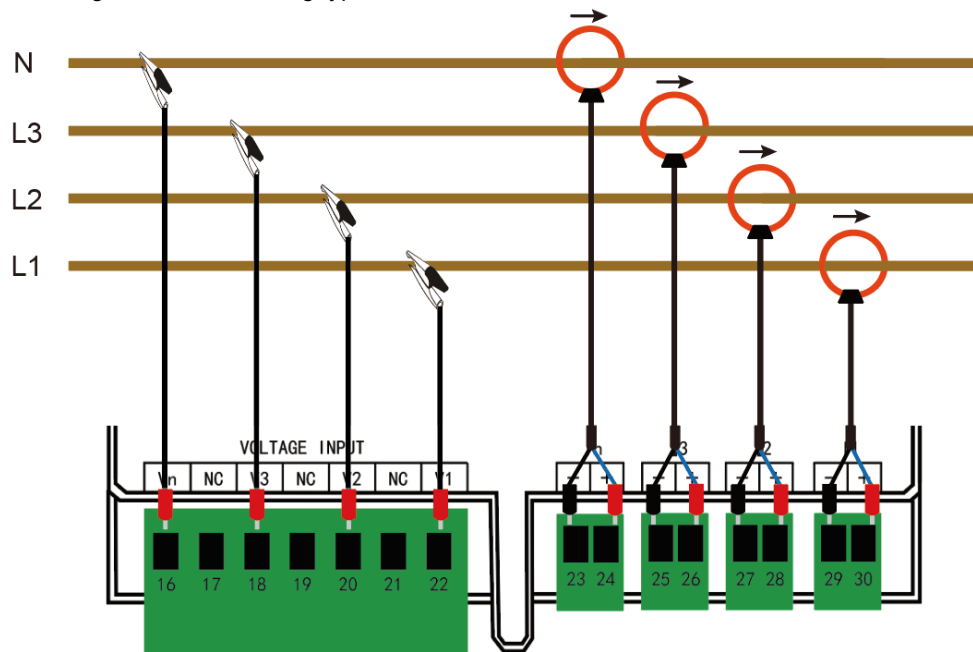

figure 6-2 Three-phase four-wire 4CT

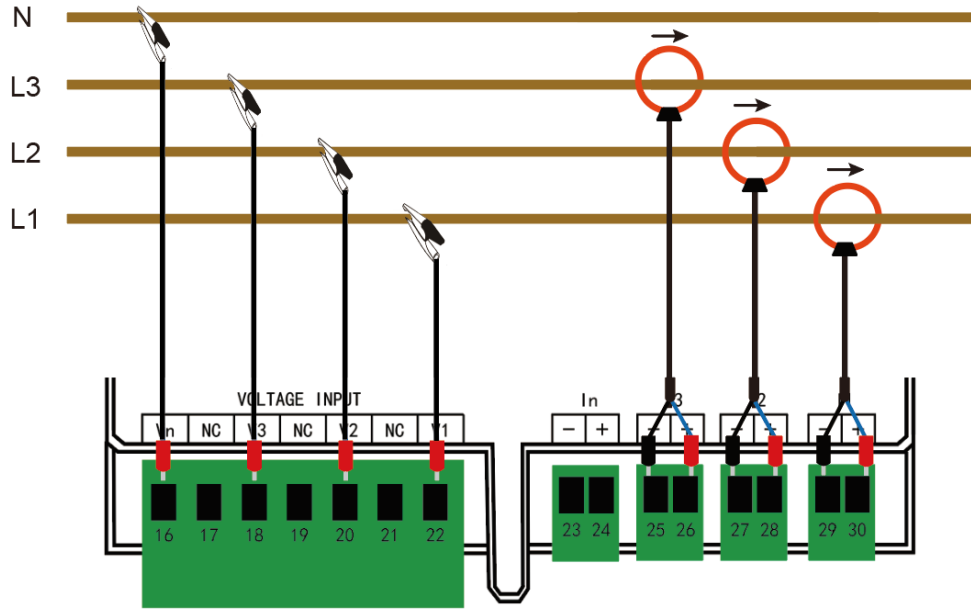

figure 6-3 Three-phase four-wire 3CT

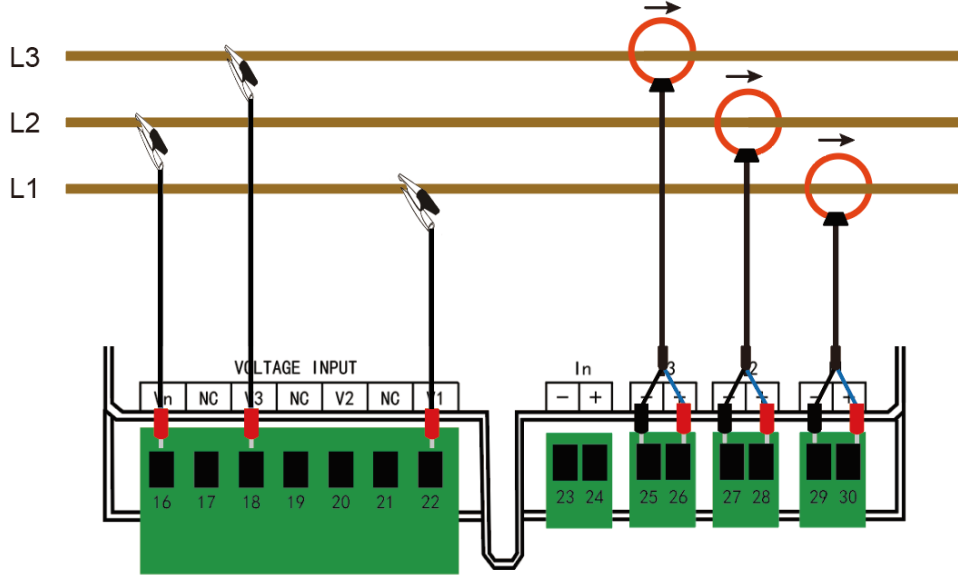

figure 6-4 Three-phase three-wire 3CT

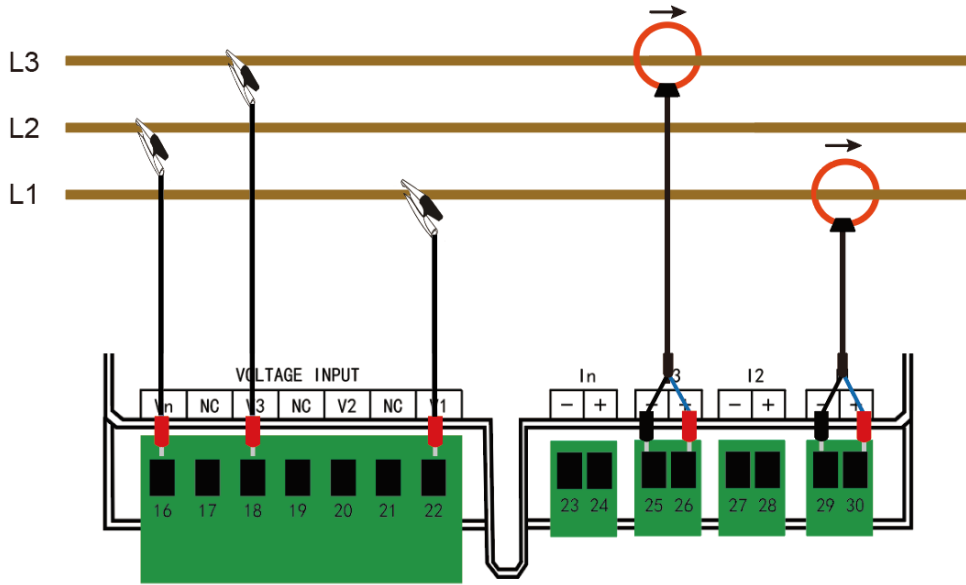

figure 6-5 Three-phase three-wire 2CT

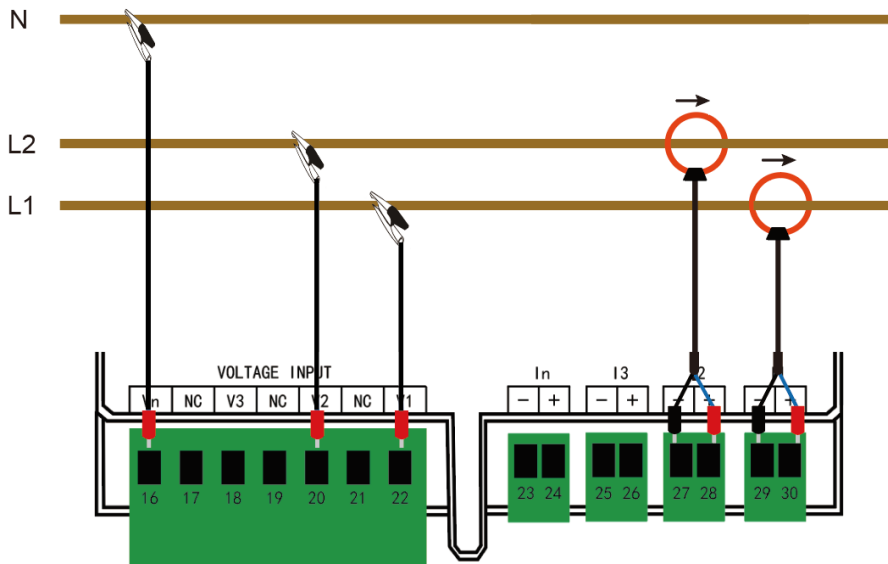

figure 6-6 Single-phase three-wire

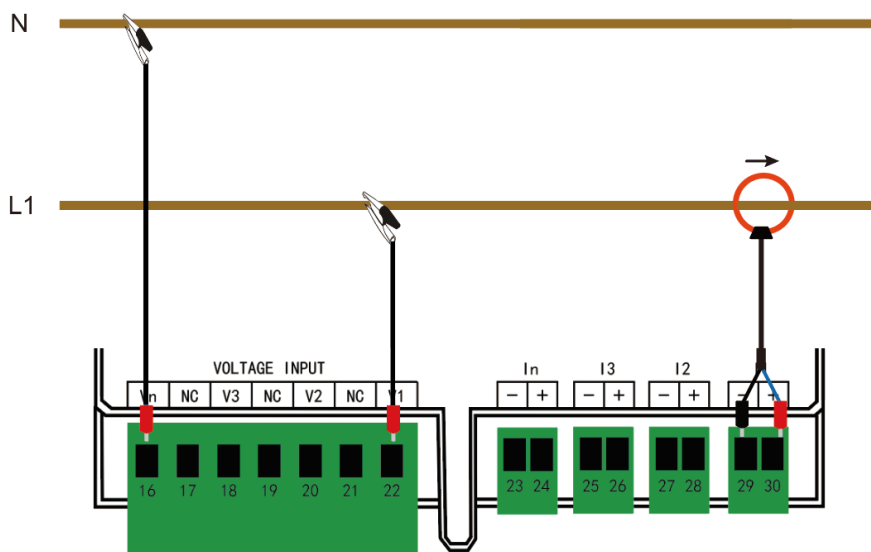
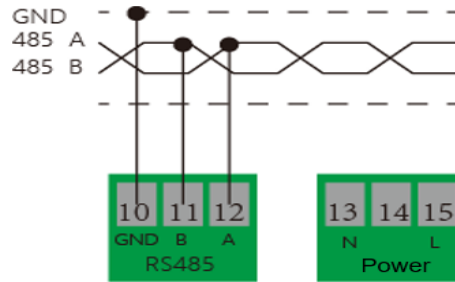

figure 6-7 Single-phase two-wire

6. 3 RS485

The electricity meter is equipped with an RS485 communication interface that supports the ModBus RTU protocol. The RS485 communication interface requires the use of shielded twisted pair connections, which are connected in the form of a daisy chain. In long-distance high-speed situations, a 120 Ω resistor needs to be connected in parallel at both ends of the daisy chain.



6. 4 Relay output

The meter is equipped with a relay output that is a normally open contact. The terminal markings are R1 and R0, where R0 is the common contact and R1 is the normally open contact. The maximum load capacity of the relay is 3A 30V DC and 3A 250V AC

The closed state of the normally open contact of the relay is displayed on the meter display interface

There are two types of relay output control modes, which can be modified through the meter operation interface or Modbus

Relay output control mode	Description
Manual	The relay output is controlled via the meter operator interface or Modbus
Alarm	The relay output is controlled by setting alarm parameters

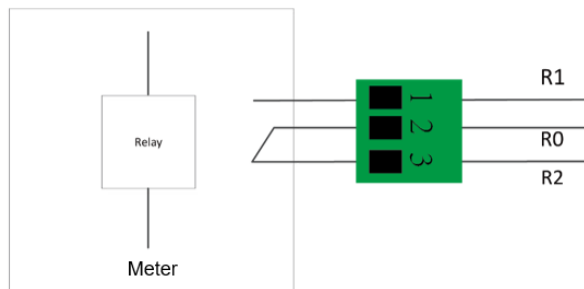

6. 5 Digital input

The meter is equipped with two digital switching inputs, which are connected by passive dry contact. The terminal blocks are identified as: DI1, DI2, DIC, where DIC is the common contact. The status of two digital switching inputs can be read through RS485/ModBus protocol, and the status of digital switching input is displayed on the meter display interface.

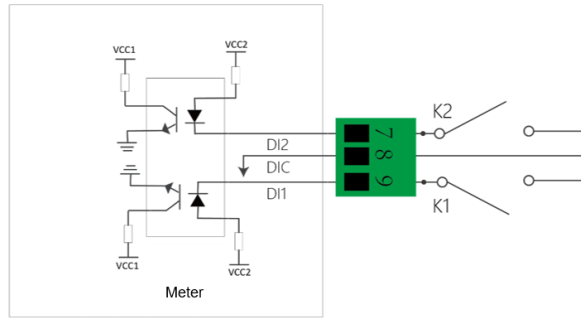

6.6 Energy pulse output

The meter is equipped with an active power pulse output, and the electric energy pulse constant EC can be viewed through the meter information interface. The internal optocoupler of the meter is isolated, the maximum allowable passing current is 80mA DC, and the working voltage range is 5V ~ 80V DC

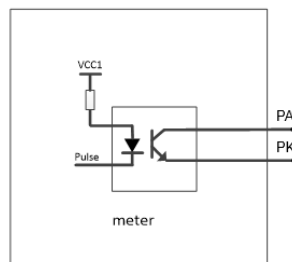

Energy pulse output connection diagram

7. Functionality

7.1 Current transformer type support

ME337N series supports current transformer types including: Rogowski coil and voltage output CT
ME337C series supports traditional current transformers, and supports direct access of up to 7A.

7.2 Current transformer orientation setting

ME337 supports current transformer direction configuration, in case of current transformer orientation error, the current transformer direction can be configured through the setting interface or Modbus.

7.3 Current transformer channel settings

The ME337 supports current transformer channel configuration, which can be configured through the setup interface or Modbus in the event that the current transformer channel and voltage channel do not match.

7.4 Multi-Tariff

ME337 provides a multi-tariff power accumulation function and supports up to 6 Tariffs.

There are two ariff switching control modes, which can be modified through the meter interface or Modbus

Tariff control mode	Description
Manual	Switch Tariff via the meter interface or Modbus
RTC	Trigger the Tariff switch through the RTC time period

7.4.1 Manual Control Mode

- **Switch Tariff through the meter setting interface**
- **Switch Tariff through Modbus configuration command 1071**

7.4.2 RTC Control Mode

In RTC control mode, the Tariff switch is triggered by the real-time clock.

The RTC control mode supports 6 time periods (Ta, Tb, Tc, Td, Te, Tf) and 6 Tariffs (T1, T2, T3, T4, T5, T6).

The time period and target tariff can be modified through Modbus.

The time period is set according to 24 hours, starting from the Ta start time, Tc start time cannot be located between Ta start time and Tb start time, Td start time cannot be between Ta start time and Tc start time, and so on.

7.5 Demand

The meter provides Active power, Reactive power, Apparent power demand and maximum demand.

The demand calculation method and demand calculation interval can be configured through the meter operation interface or Modbus.

7.5.1 Demand Calculation Method

The meter supports two demand calculation methods: fixed and sliding.

Demand Calculation Method	Description
fixed	The meter calculates and updates demand at the end of each interval
sliding	Demand is updated every 1 minute

The following figure introduces two methods of demand calculation, taking the demand interval of 15 minutes as an example:

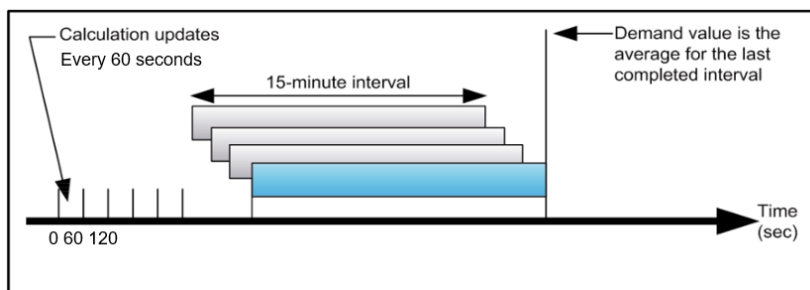

figure 7-1 Sliding

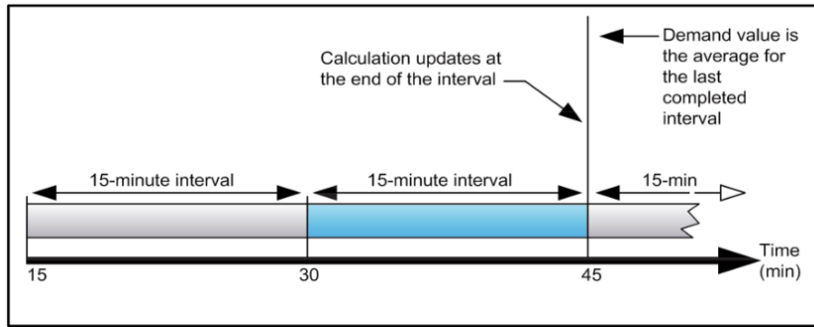

figure 7-2 fixed

7.6 Alarm

The meter provides a variety of alarm parameter settings and alarm outputs, and the alarm parameters can be configured through Modbus.

Alarm type	Description
Over current, each phase	If a phase value exceeds the alarm threshold, an alarm is generated. When all phases are less than the release threshold, the alarm is released
Under current, each phase	If a phase value exceeds the alarm threshold, an alarm is generated. When all phases are greater than the release threshold, the alarm is released
Over phase voltage, each phase	If a phase value exceeds the alarm threshold, an alarm is generated. When all phases are less than the release threshold, the alarm is released
Under phase voltage, each phase	If a phase value exceeds the alarm threshold, an alarm is generated. When all phases are greater than the release threshold, the alarm is released
Over line voltage, each phase	If a phase value exceeds the alarm threshold, an alarm is generated. When all phases are less than the release threshold, the alarm is released
Under line voltage, each phase	If a phase value exceeds the alarm threshold, an alarm is generated. When all phases are greater than the release threshold, the alarm is released
Over power, Total Active Power (absolute)	
Over power, Total Reactive Power (absolute)	
Over power, Total Apparent Power	
Over demand, total Active power (absolute), current	
Over demand, total reactive power (absolute value), current	
Over demand, total apparent power, current	



Alarm type	Description
Over THD-U, each phase	If a phase value exceeds the alarm threshold, an alarm is generated. When all phases are less than the release threshold, the alarm is released
Over THD-I, each phase	If a phase value exceeds the alarm threshold, an alarm is generated. When all phases are less than the release threshold, the alarm is released

7.6.1 Alarm output

The alarm output can be associated with the buzzer and relay output (relay control mode needs to be configured as alarm mode), and the corresponding output will also be released when the alarm is released, see 9.9.17

7.7 Phase sequence detection

The meter supports three-phase voltage and current phase sequence detection, and the phase sequence can be viewed on the meter interface or the phase sequence status can be read through Modbus.

Phase sequence status marker	Description
 flashing	The voltage phase sequence is wrong
 flashing	The current phase sequence is wrong
 flashing	The voltage and current phase sequence is wrong
No display	The phase sequence is correct

Note: The correct phase sequence of voltage and current can only ensure that the respective phase sequence is correct, and cannot guarantee the correspondence between voltage and current, so you need to pay attention to the wiring method

8. Interface display and operation

This section describes the display of the interface and the operation of key combinations, as well as the configuration of the device.

8.1 Display interface and buttons

The meter adopts LCD display and 4 control buttons, and all the display segments of the screen are shown in the figure below:

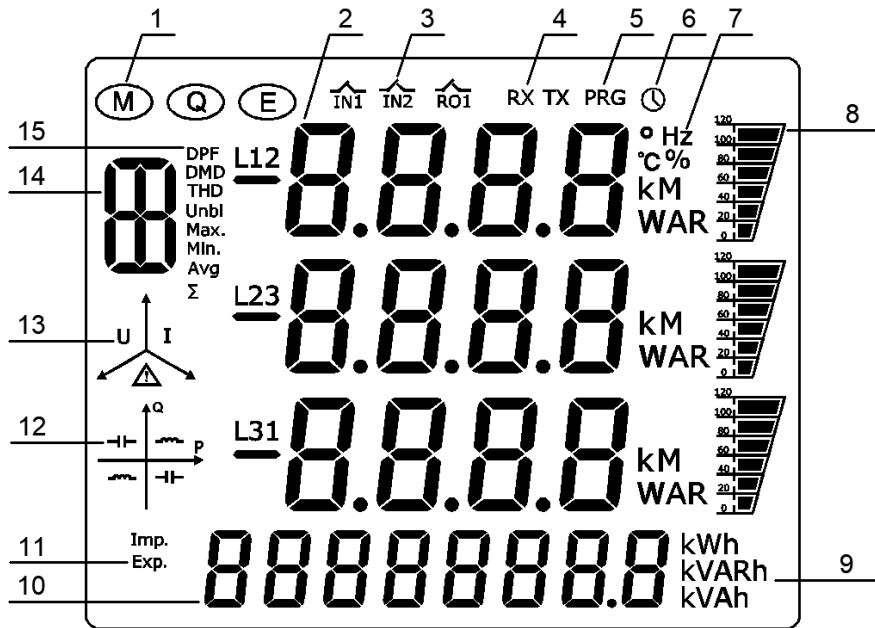

Interface Symbol Description

No.	Symbol	Description
1	(M) (Q) (E)	(M) : Indicates that the current interface is a real-time measurement data display (Q) : Indicates that the current interface is a power quality display (E) : Indicates that the current interface is is a energy display
2	8	Used to display various data
3	INI INZ ROI	INI : Status display for digital input channel 1 INZ : Status display for digital input channel 2 ROI : Status display of relay output channel
4	RX TX	The communication status is displayed, when there is data sent and received, RX TX will be displayed, otherwise there will be no display
5	PRG	Device configuration mode displays, in which device parameters can be configured
6	🕒	Device information mode display, in which you can view device information
7	Measurement data units	Voltage:V,KV,MV Current:A,KA,MA Active power:W,KW,MW Reactive power:VAR,KVAR,MVAR Apparent power:VA,KVA,MVA Frequency:Hz Percentage:%
8	📊	Voltage, current, power as a percentage of nominal value is displayed
9	kWh kVARh kVAh	Energy unit display Active Energy:kWh Reactive Energy:kVARh Apparent Energy:kVAh
10	8	Energy value display

No.	Symbol	Description
11	Imp. Exp.	Energy positive and negative displays positive Energy:Imp.; negative Energy:Exp.
12		Power quadrant and load capacitance display
13		Voltage and current phase sequence display When the voltage phase sequence is incorrect, flashes When the current phase sequence is incorrect, flashes
14		Used to display data types: Voltage:U Current:I Active power:P Reactive power:Q Apparent power:S Energy:E
15	DPF DMD THD Unbl Max. Min. Avg Σ	Types of power quality parameters: Power factor:PF Displacement power factor:DPF Demand:DMD Total harmonics Distortion:THD, Unbalance:Unbl Maximum:Max. Minimum:Min. Average:Avg Total:Σ

The four buttons of the meter are shown below:



Key function display description:

Key symbol	Description
	Back key: Used to exit the current operation interface
	Up key: Used to switch the interface display and change the value size during setting, long press to shift
	Down key: Used to switch the interface display and change the value size during setting, long press to shift
	Confirm key: Used to confirm the operation

8. 2 Meter start-up interface

After the meter is powered on, the following screen is displayed:



8. 3 Meter display mode switching

The meter display mode is divided into data display mode and device configuration mode.



The data display mode and device configuration mode are switched by **ESC** key

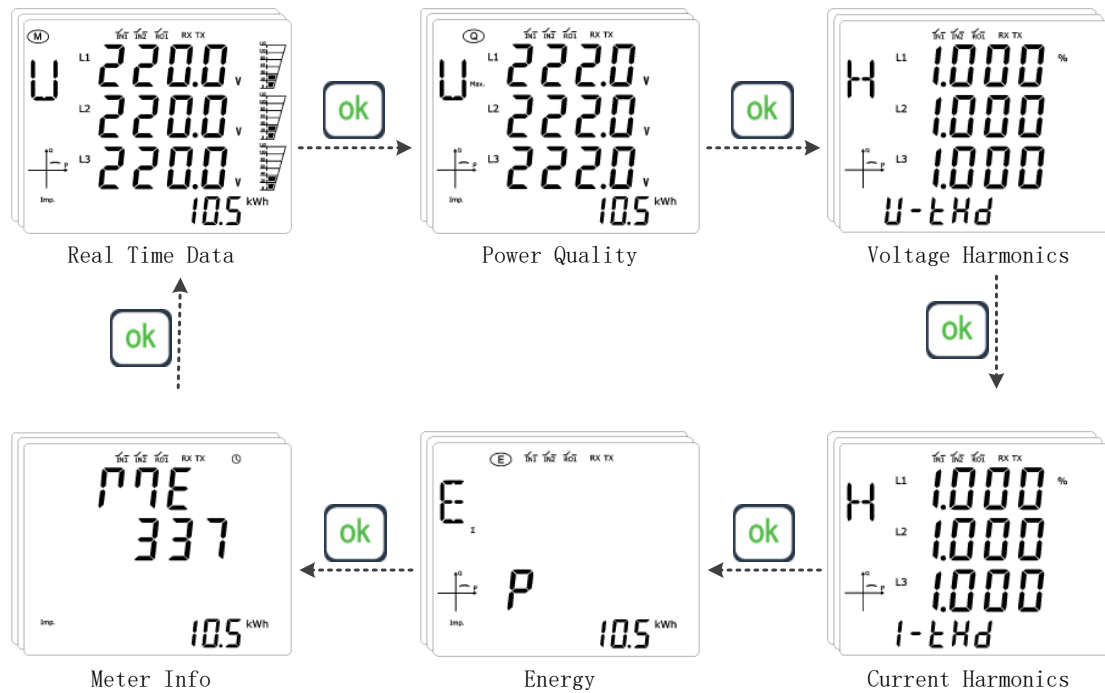

There are a total of 6 display modes in the data display mode: real-time measurement data display mode (M), power quality display mode (Q), voltage harmonic display mode, current harmonic display mode, Energy display mode (E), device information display mode (I), and switch between each mode by **ok** key, as shown in the figure below:



8. 4 Real-time measurement data interface

Figure (M) display, indicating that the current mode is real-time measurement data mode, real-time measurement data display interface is used to display: voltage, current, power, power factor, frequency and other data. Use the  key or  key to toggle the display of the interface.

The meter will have different display interfaces under different wiring types:

8.4.1 Real-time measurement data interface 3P4W

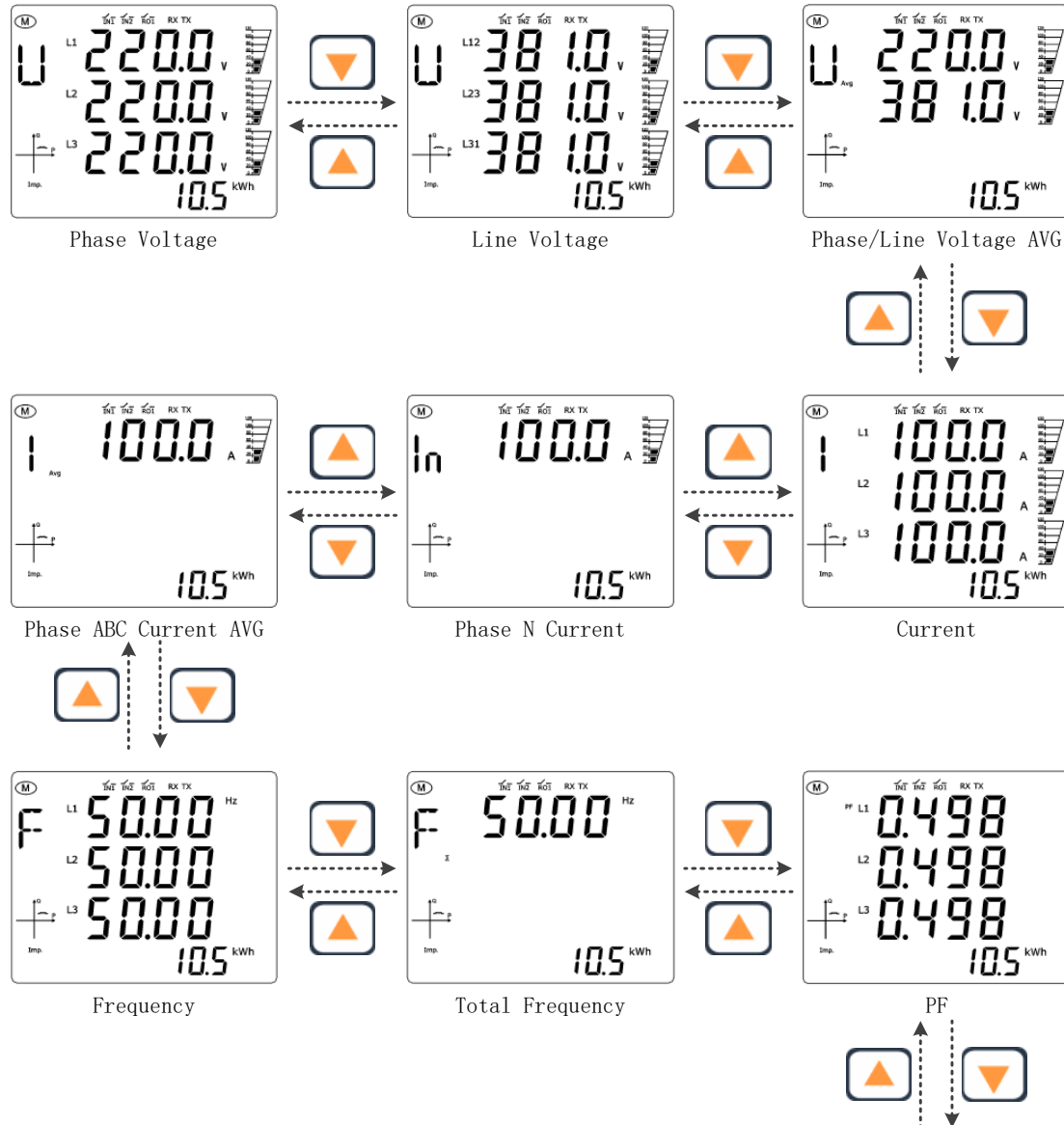

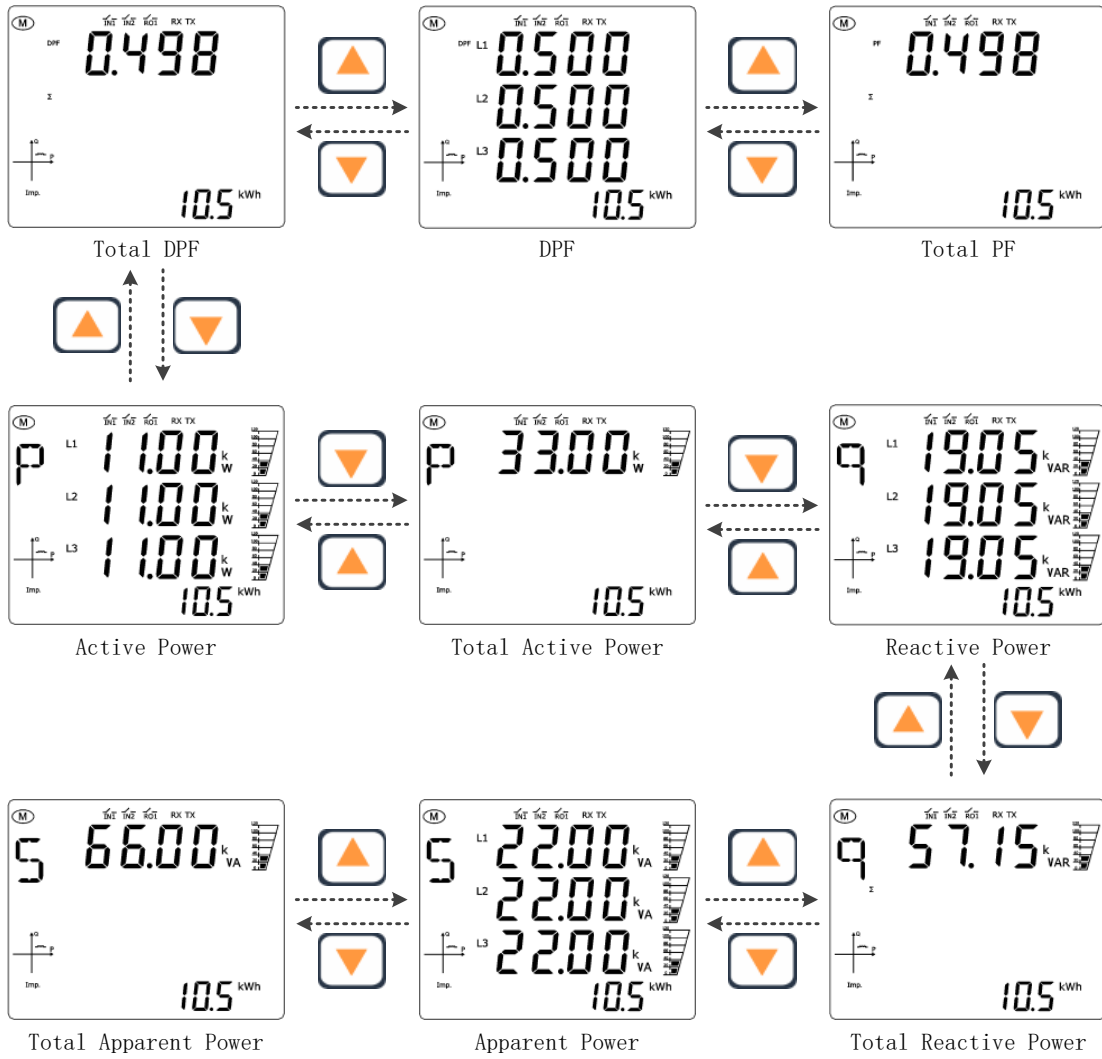

8.4.2 Real-time measurement data interface 3P3W

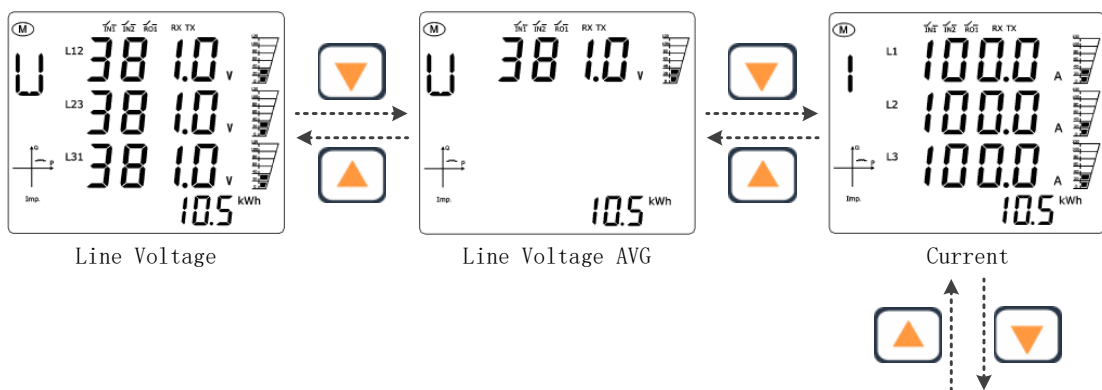

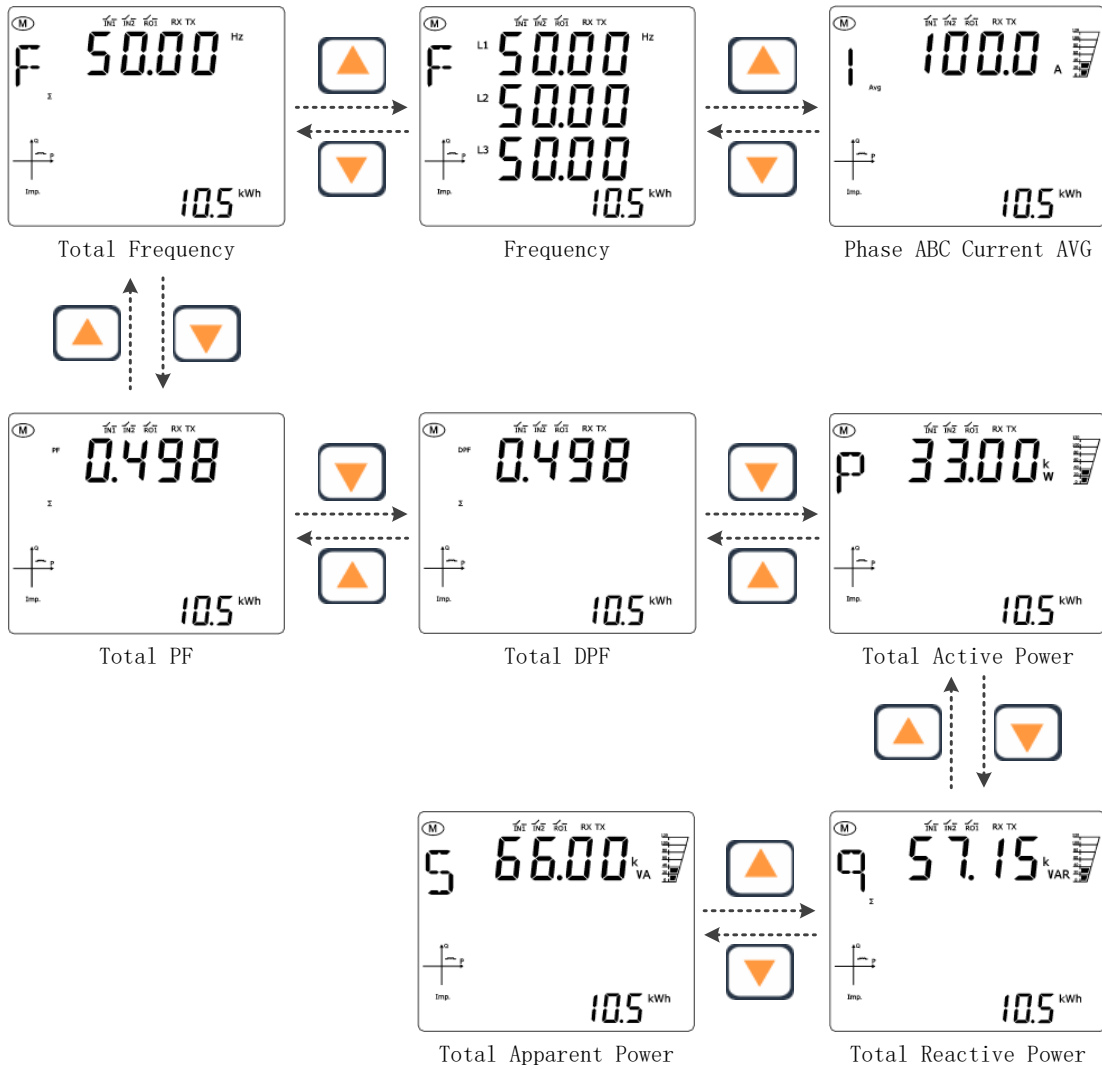

8.4.3 Real-time measurement data interface 1P3W

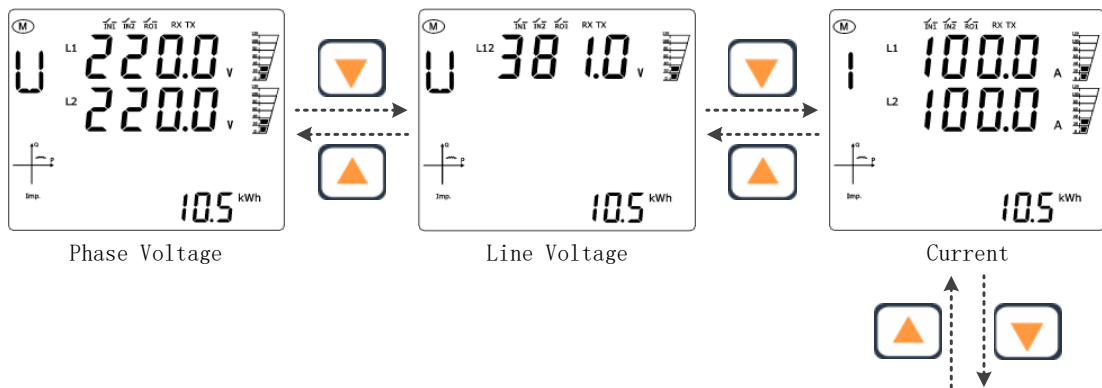

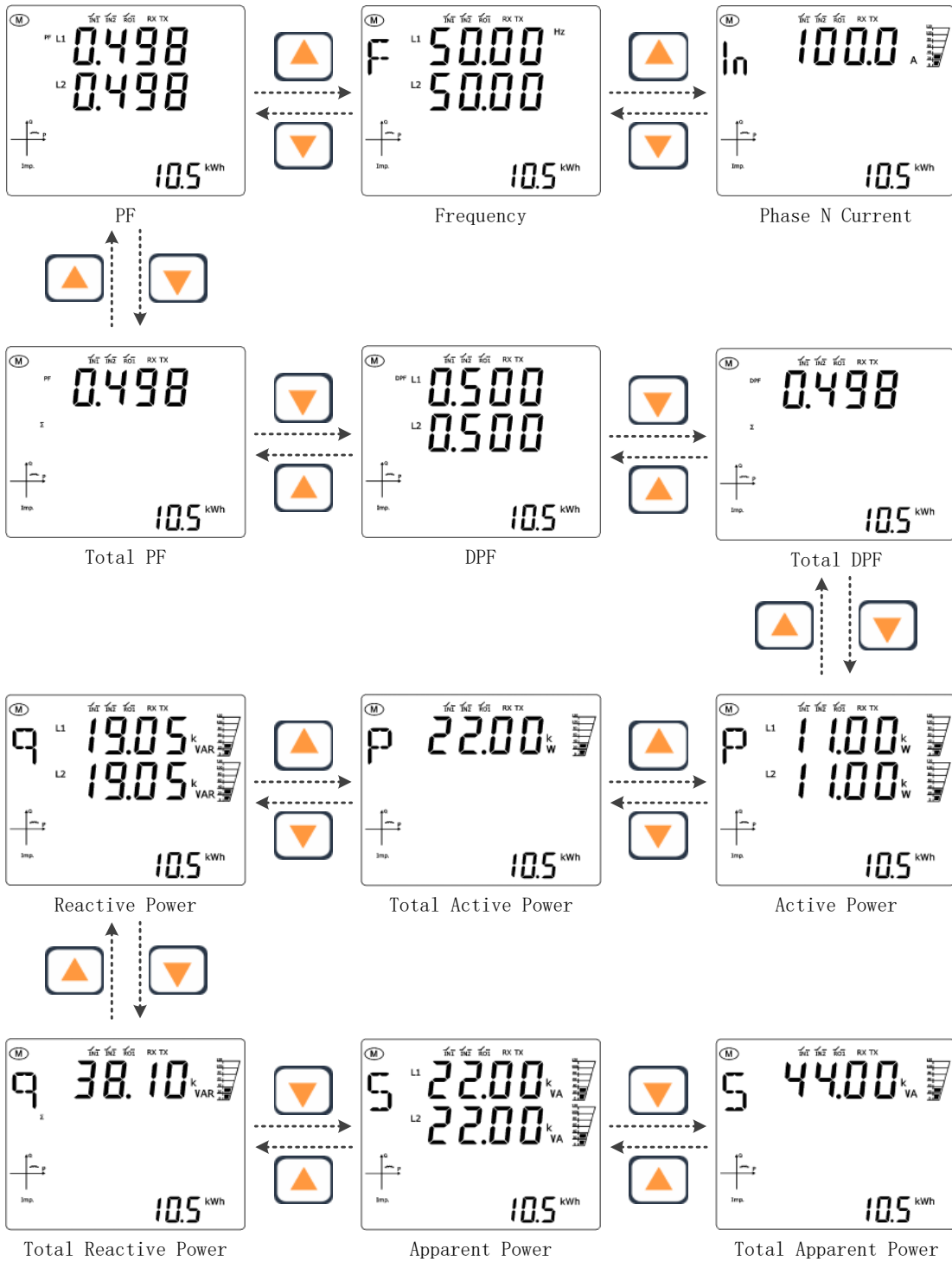

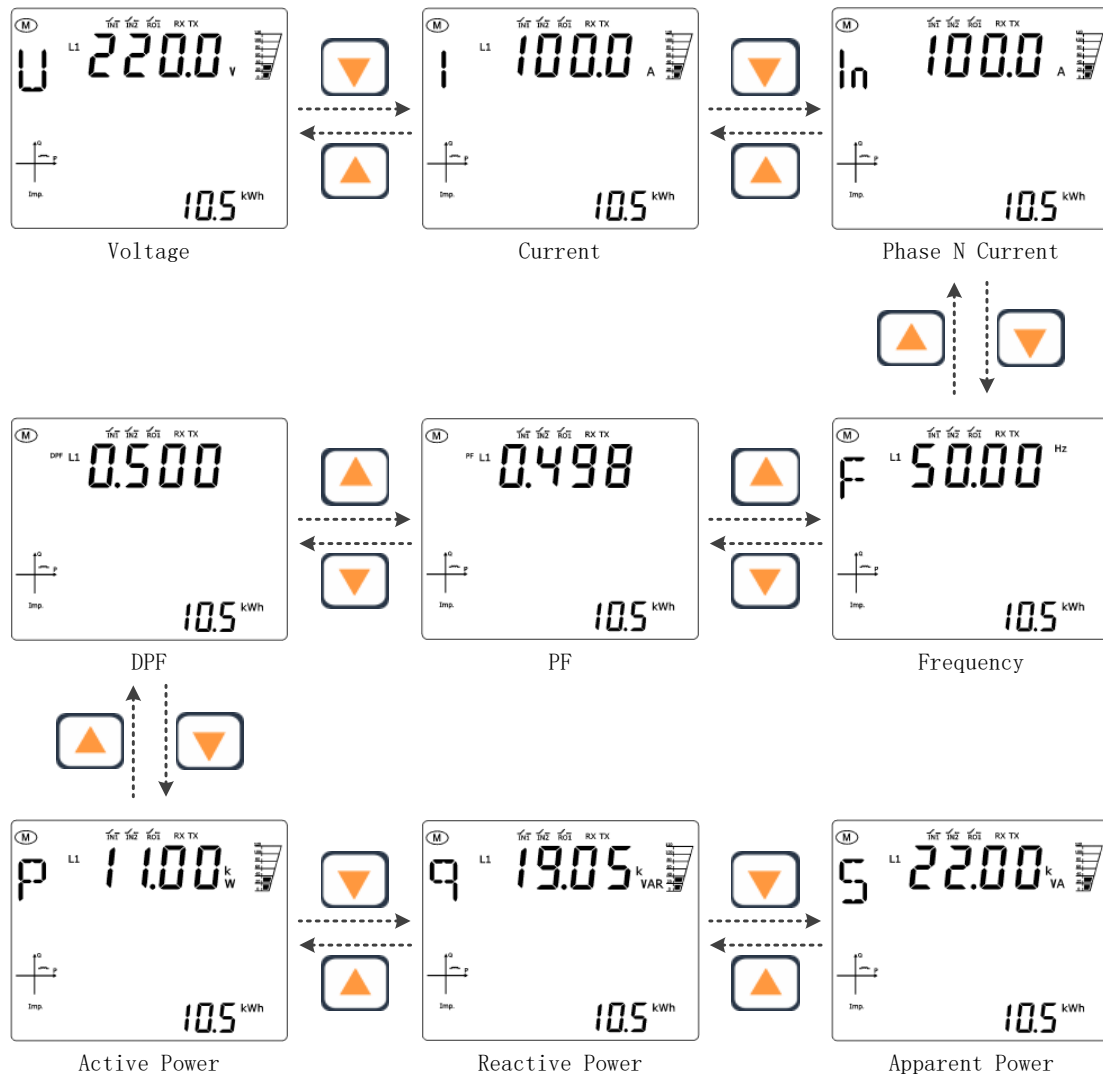

8.4.4 Real-time measurement data interface 1P2W



8.5 Power quality interface

Figure ④ indicator display, indicating that the current mode is power quality mode, power quality display interface is used to display: voltage and current power maximum and minimum value, voltage and current imbalance, current power demand and other data. Use the  key or  key to toggle the display of the interface.

The power quality display interface will have different display interfaces under different wiring methods.

8.5.1 Power quality interface 3P4W

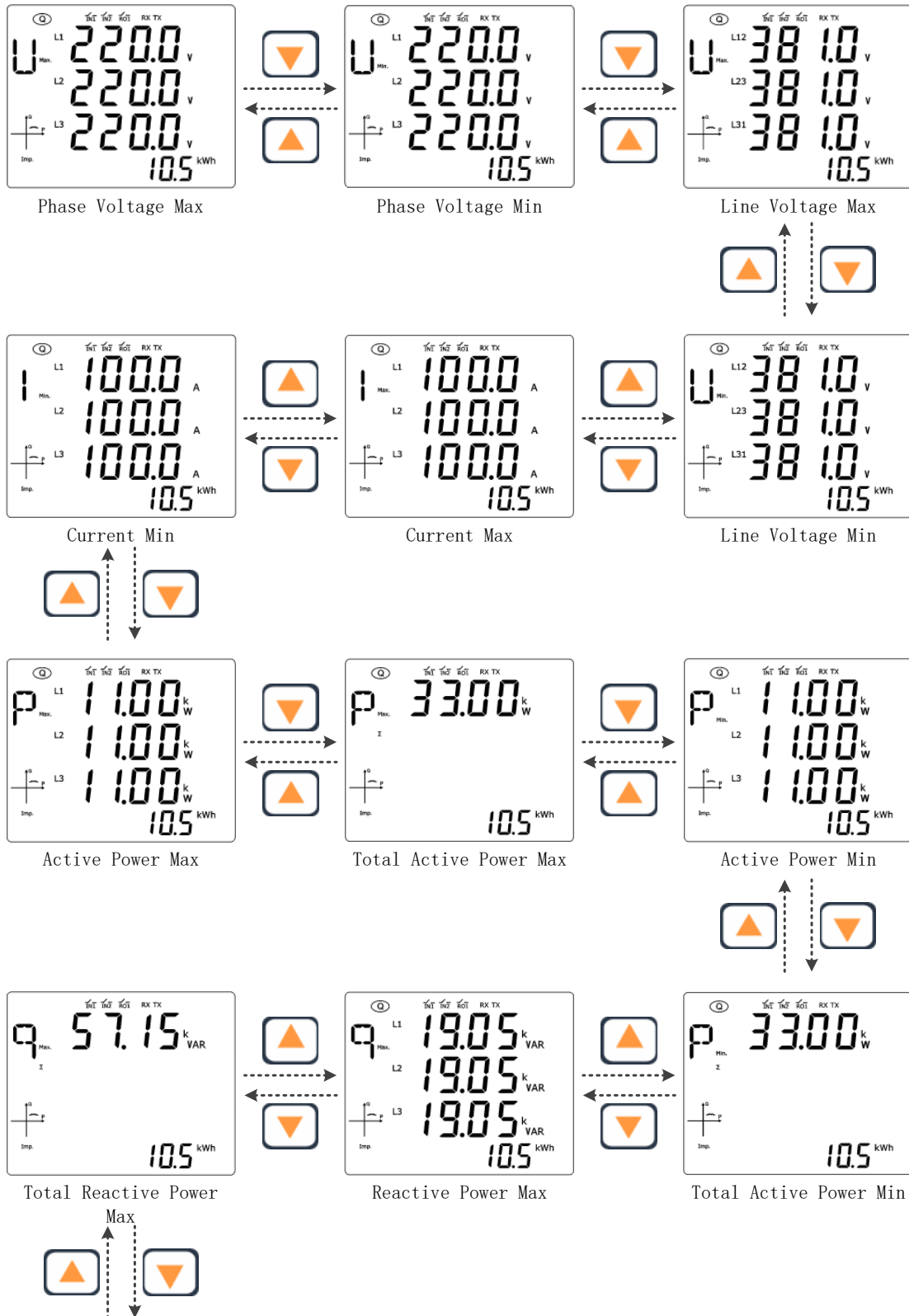

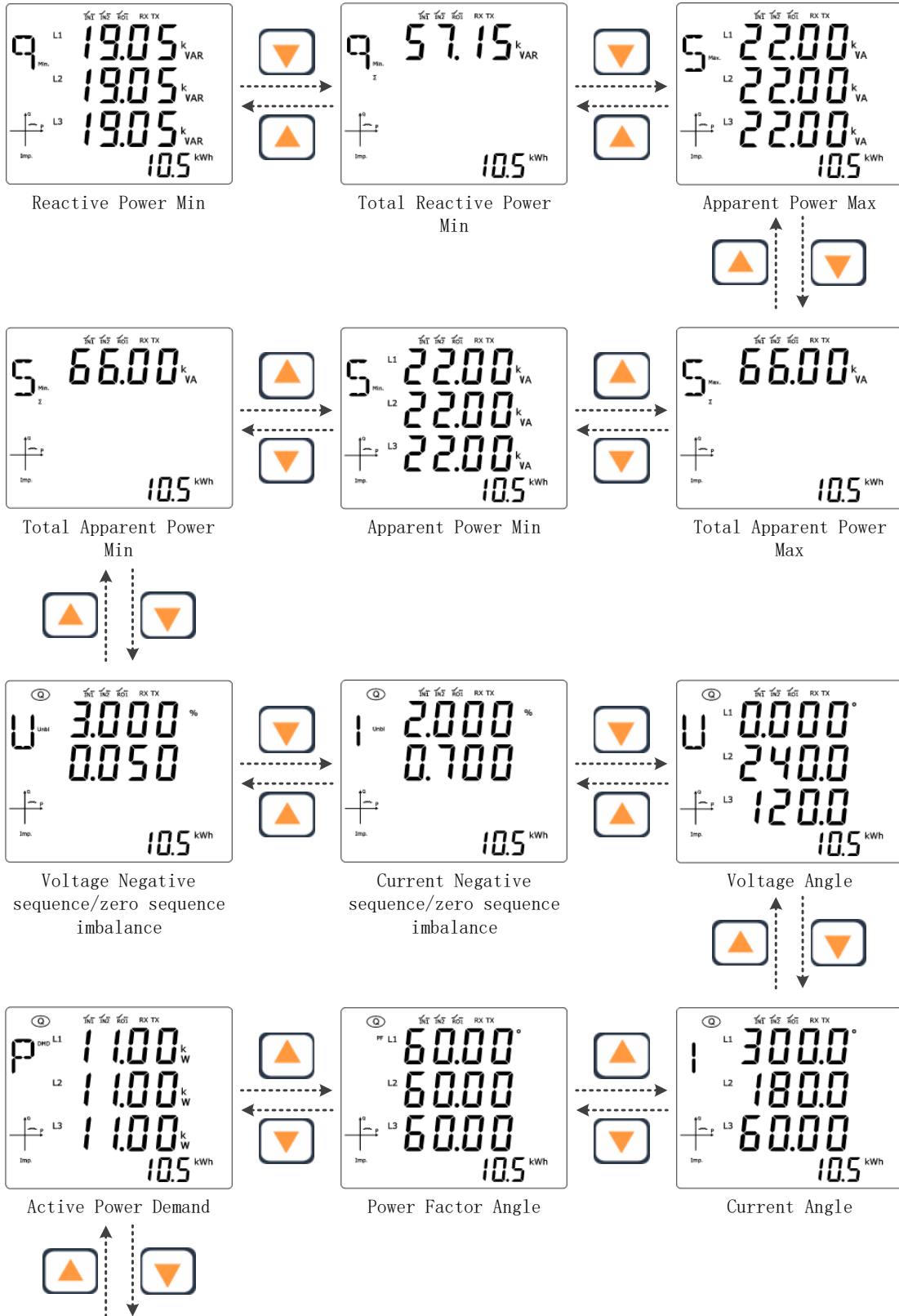

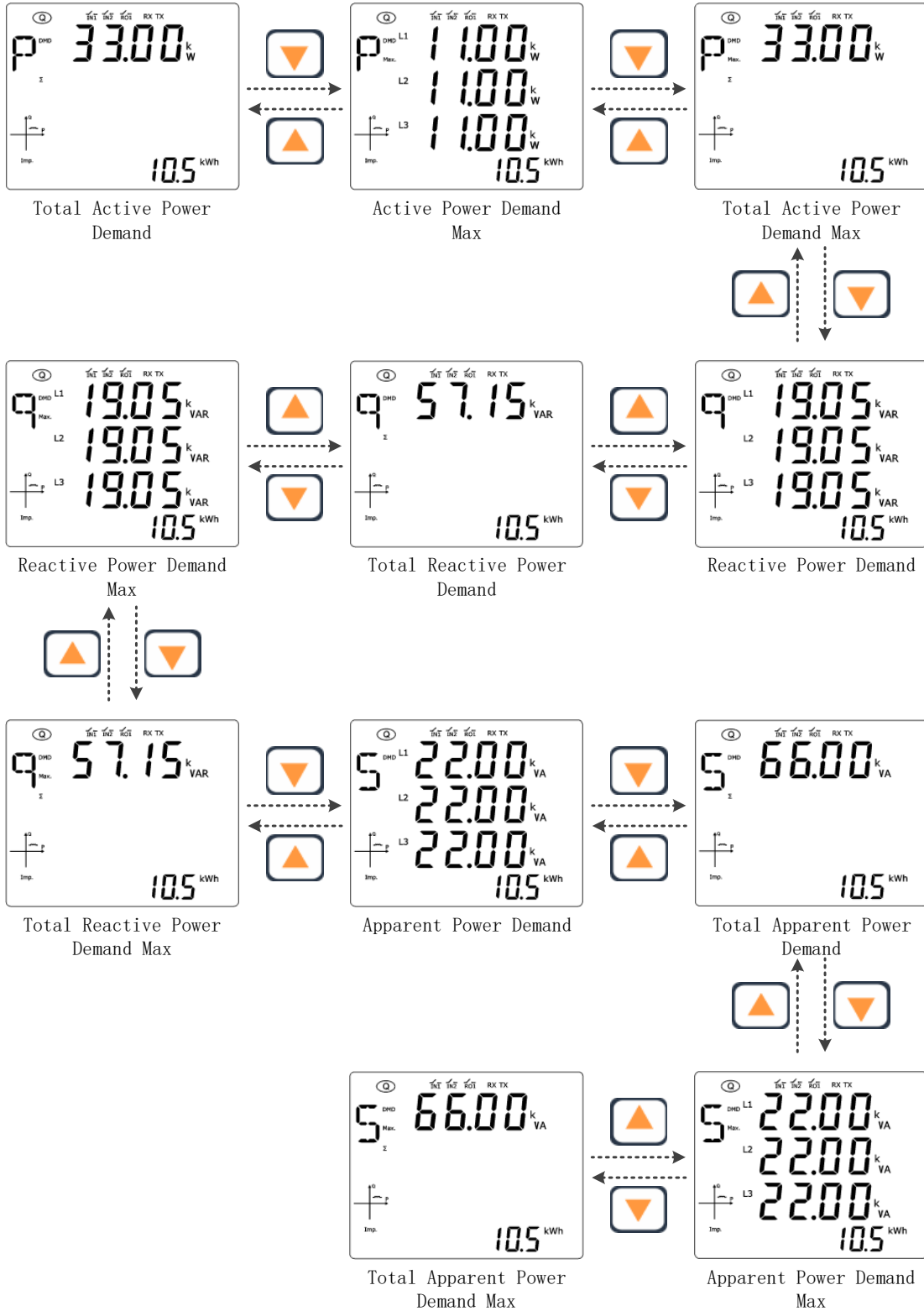

8.5.2 Power quality interface 3P3W

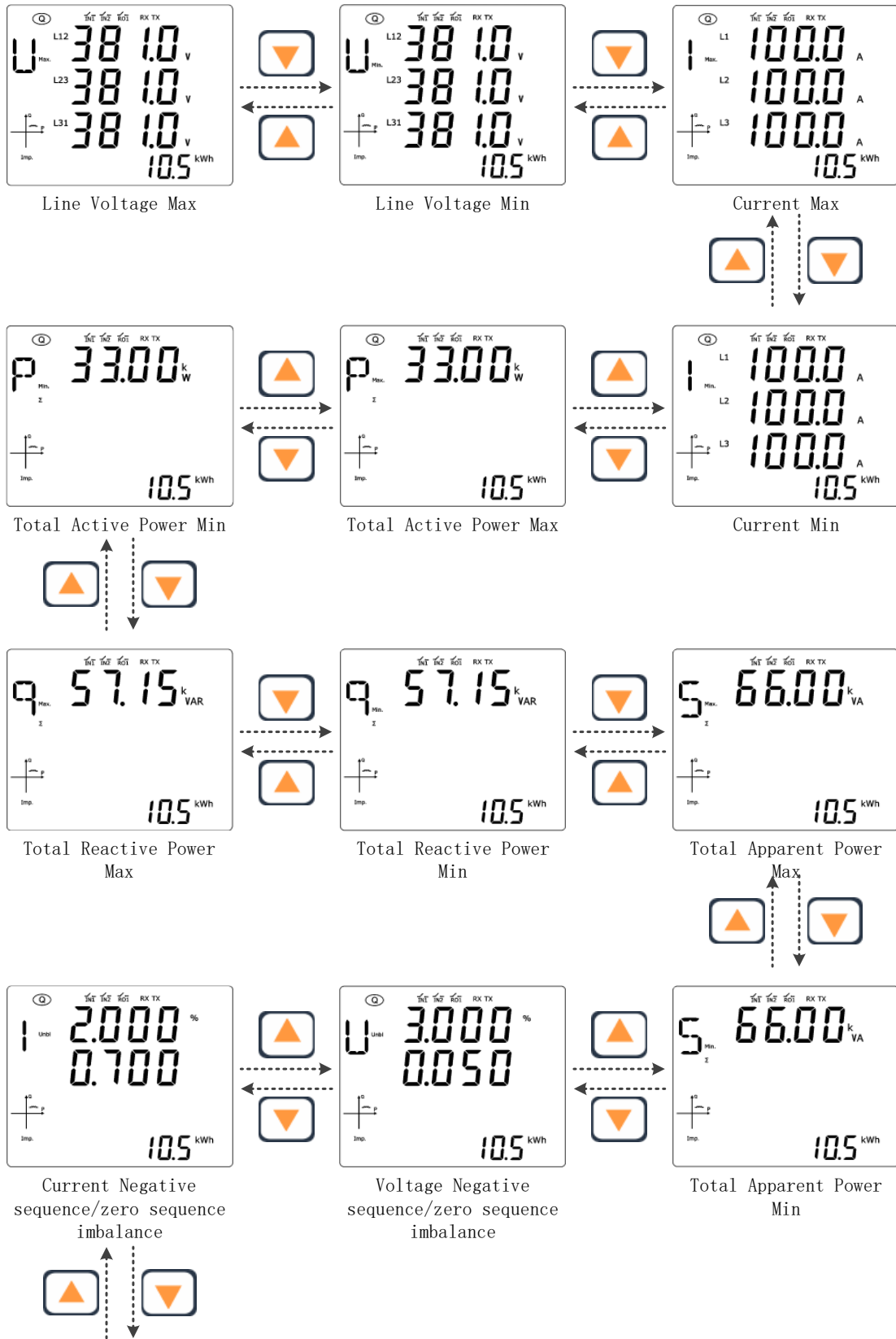

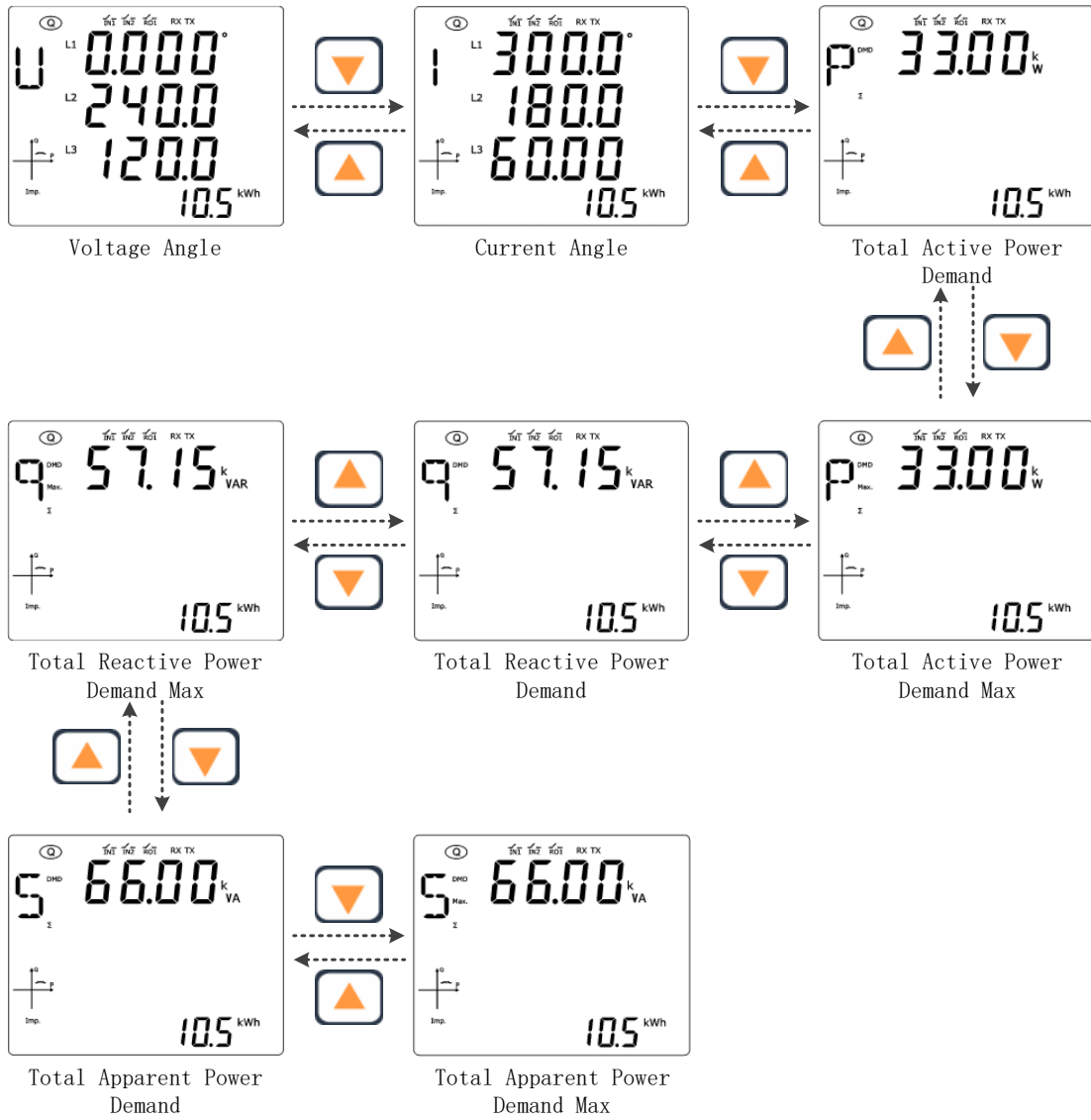

8.5.3 Power quality interface 1P3W

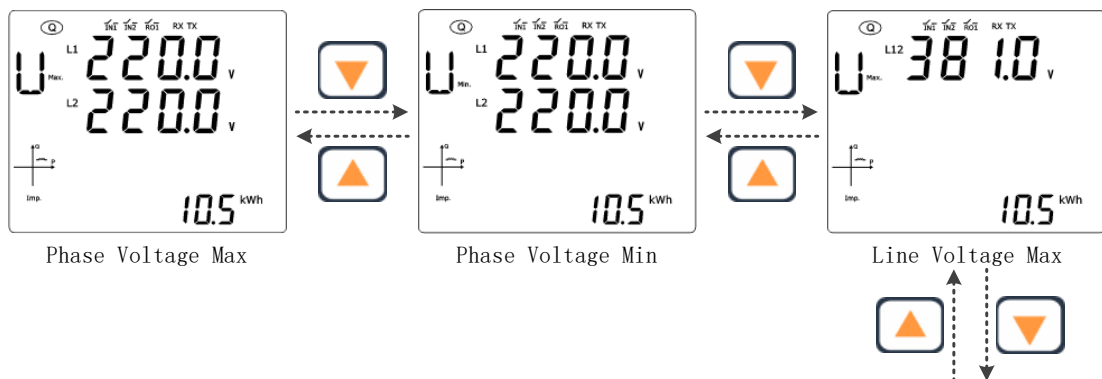

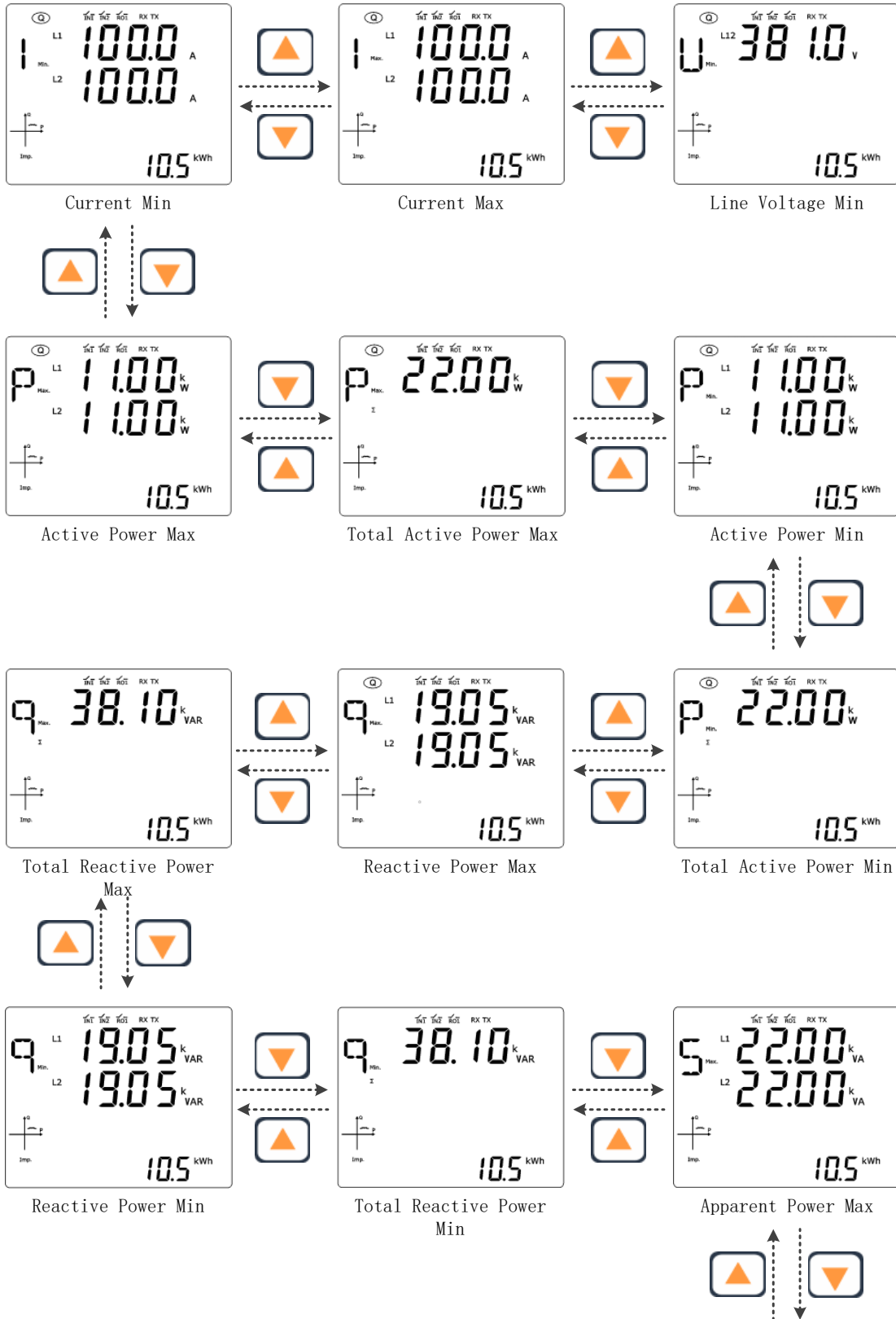

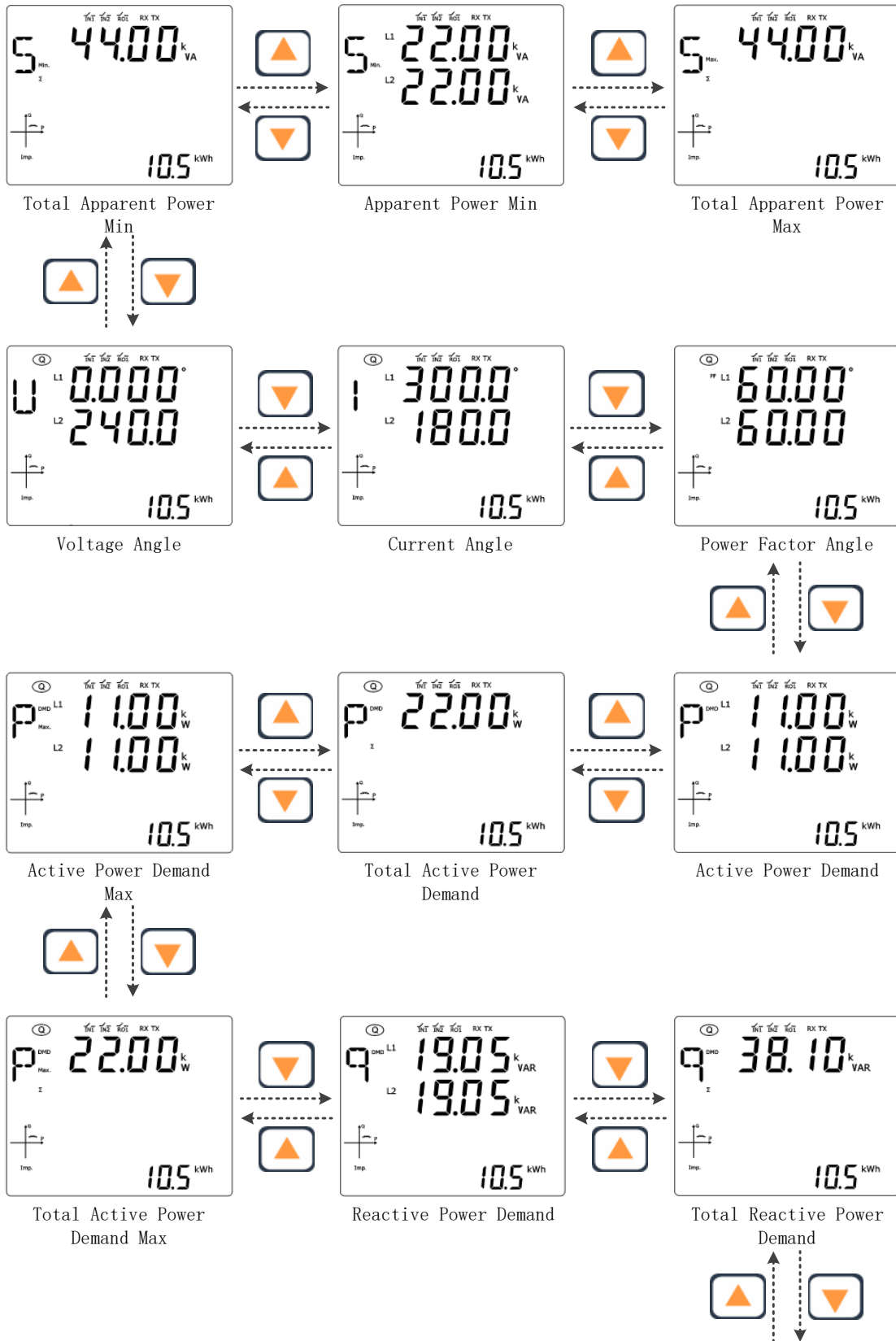

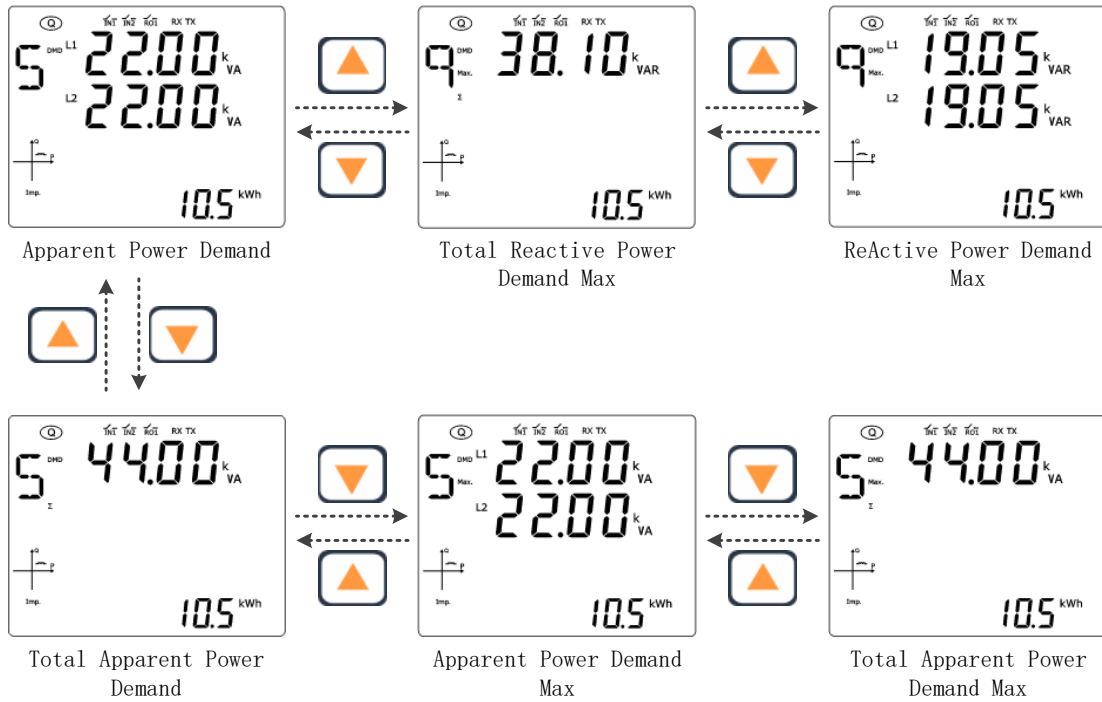

8.5.4 Power quality interface 1P2W

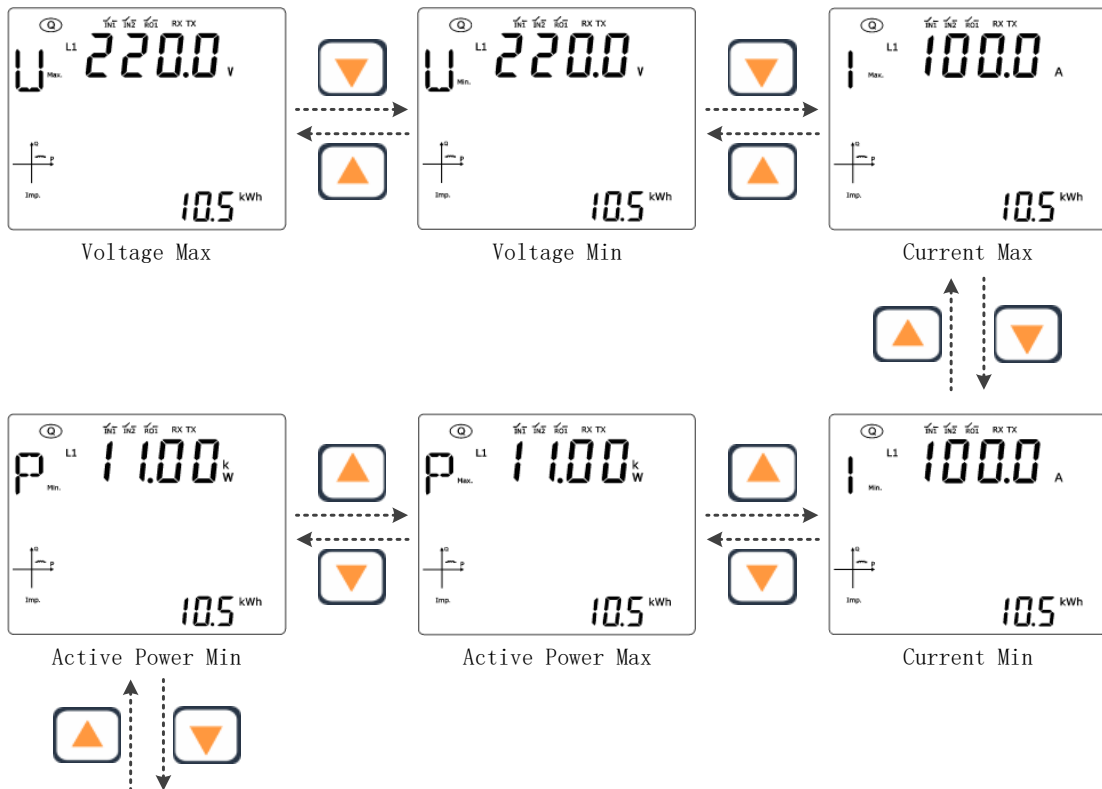

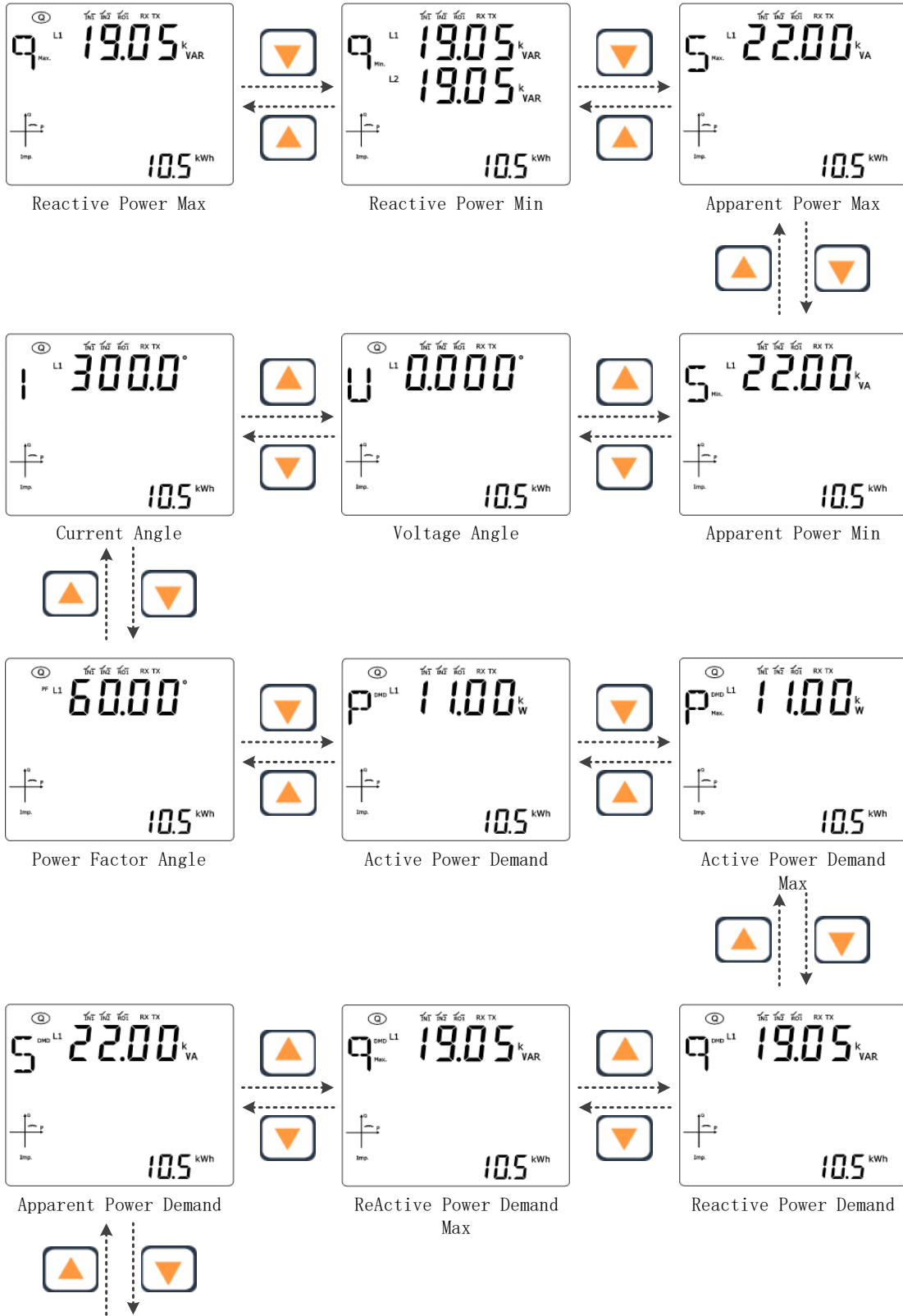

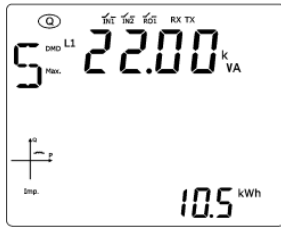



Apparent Power Demand
Max

8.6 Voltage Harmonic Interface

The voltage harmonic display interface is used to display: total voltage harmonics and fractional voltage harmonics and other data. Use the  key or  key to toggle the display of the interface.

The voltage harmonic display interface will have different display interfaces under different wiring types

8.6.1 Voltage harmonic interface 3P4W

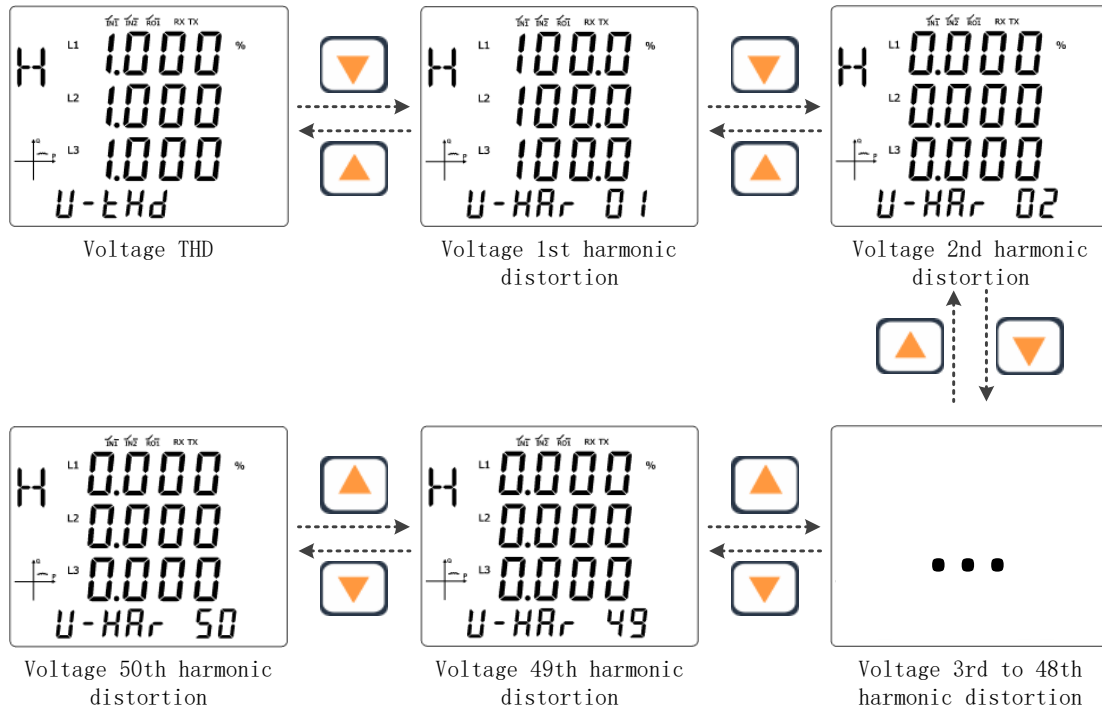

8.6.2 Voltage harmonic interface 3P3W

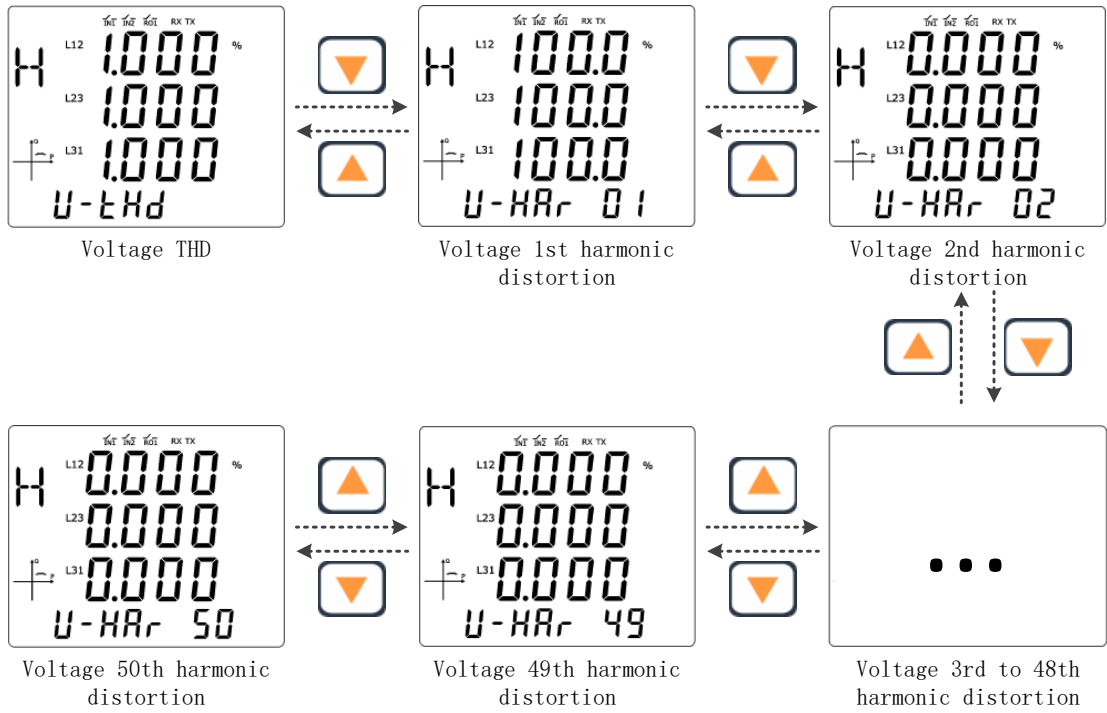

8.6.3 Voltage harmonic interface 1P3W

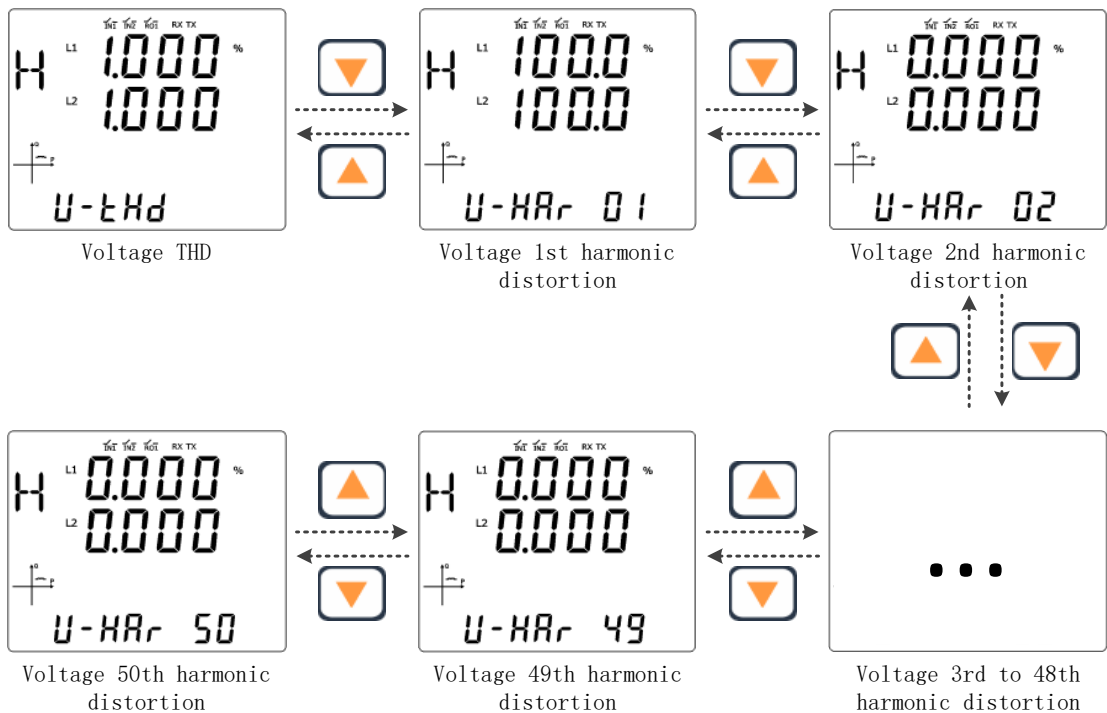

8.6.4 Voltage harmonic interface 1P2W

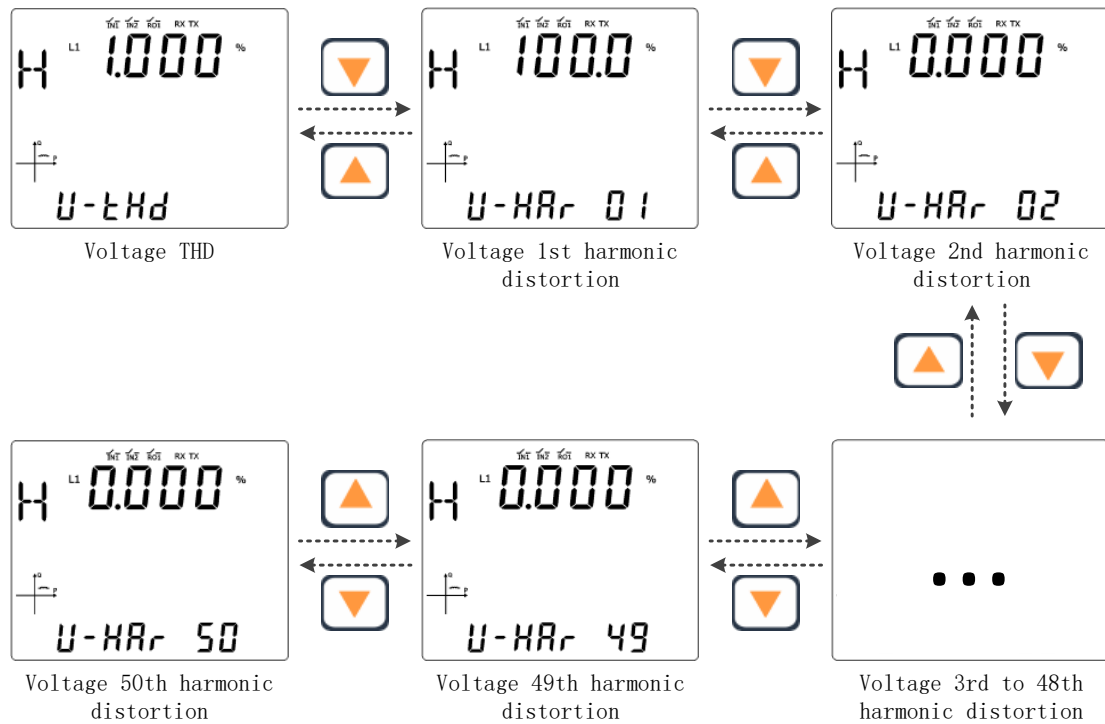

8.7 Current Harmonic Interface

The current harmonic display interface is used to display: total current harmonic and fractional voltage harmonics and other data. Use the key or key to toggle the display of the interface.

The current harmonic display interface will have different display interfaces under different wiring methods.

8.7.1 Current Harmonic Interface 3P4W

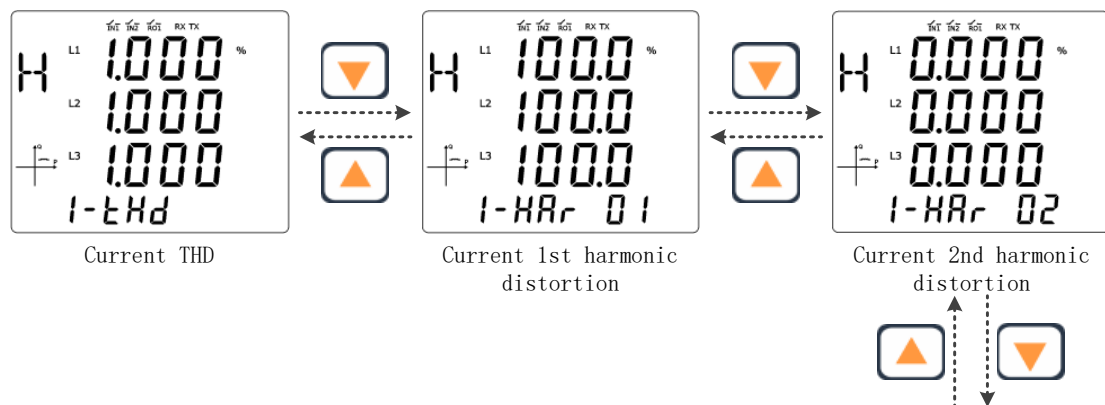

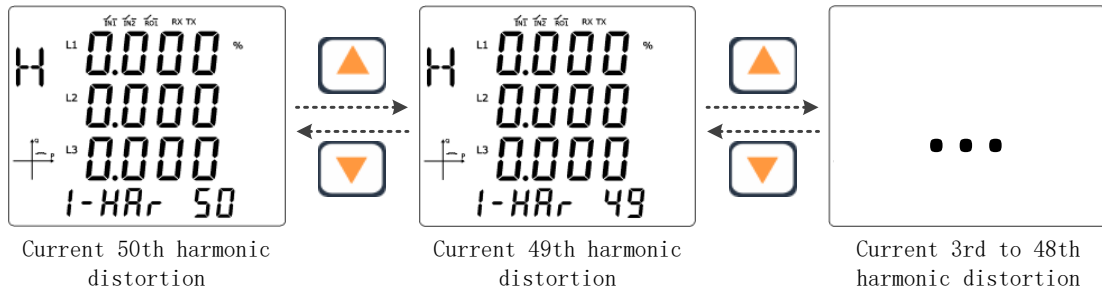

8.7.2 Current Harmonic Interface 3P3W

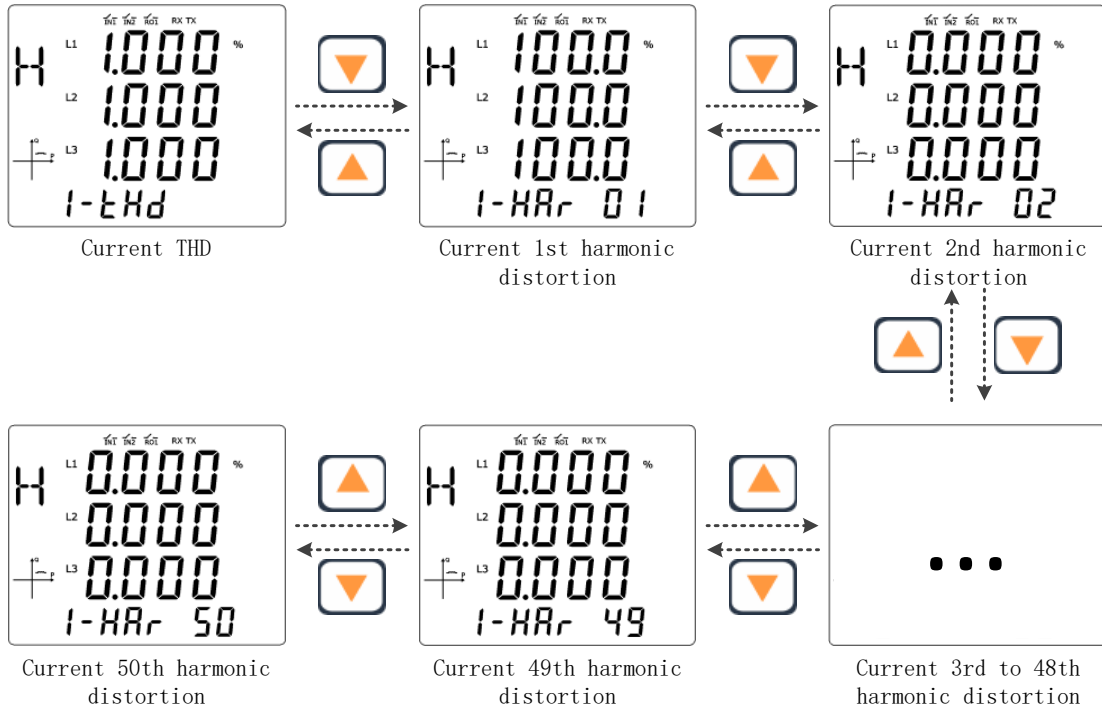

8.7.3 Current Harmonic Interface 1P3W

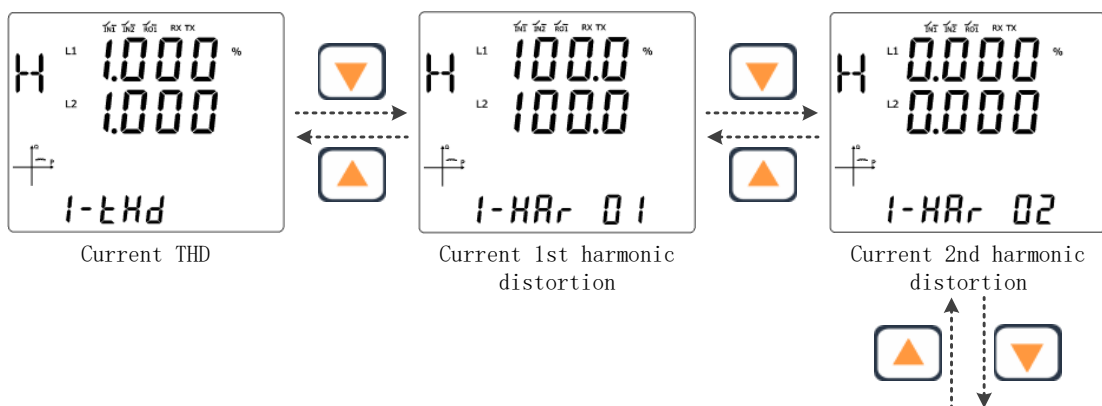

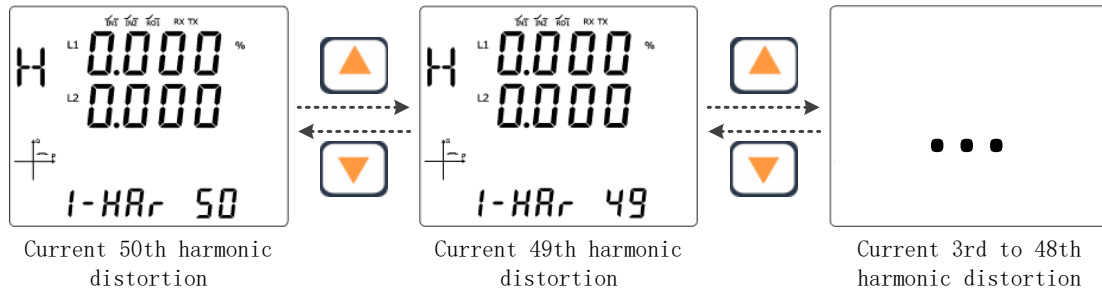

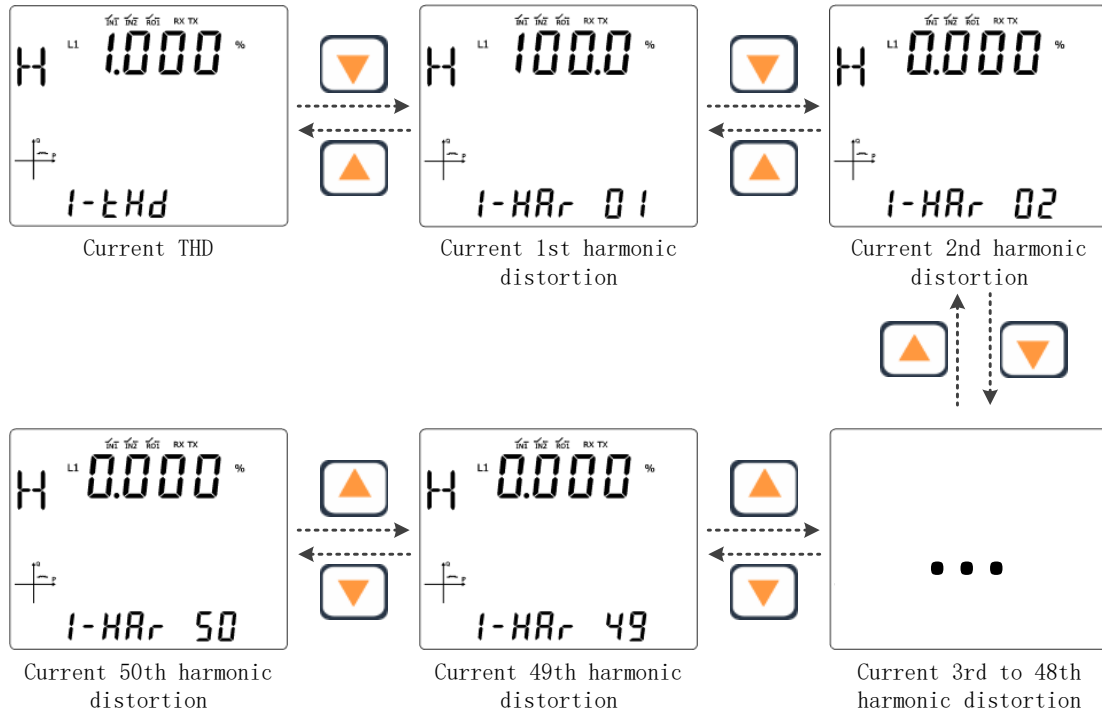

8.7.4 Current Harmonic Interface 1P2W



8.8 Energy Data Interface

Figure (E) display, indicating that the current mode is Energy data display mode, Energy data display interface is used to display: Active Energy, Reactive Energy, Apparent Energy, Tariff Energy and other data. Use the  key or  key to toggle the display of the interface.

The meter will have different display interfaces under different wiring methods.

8.8.1 Energy Data Interface 3P4W

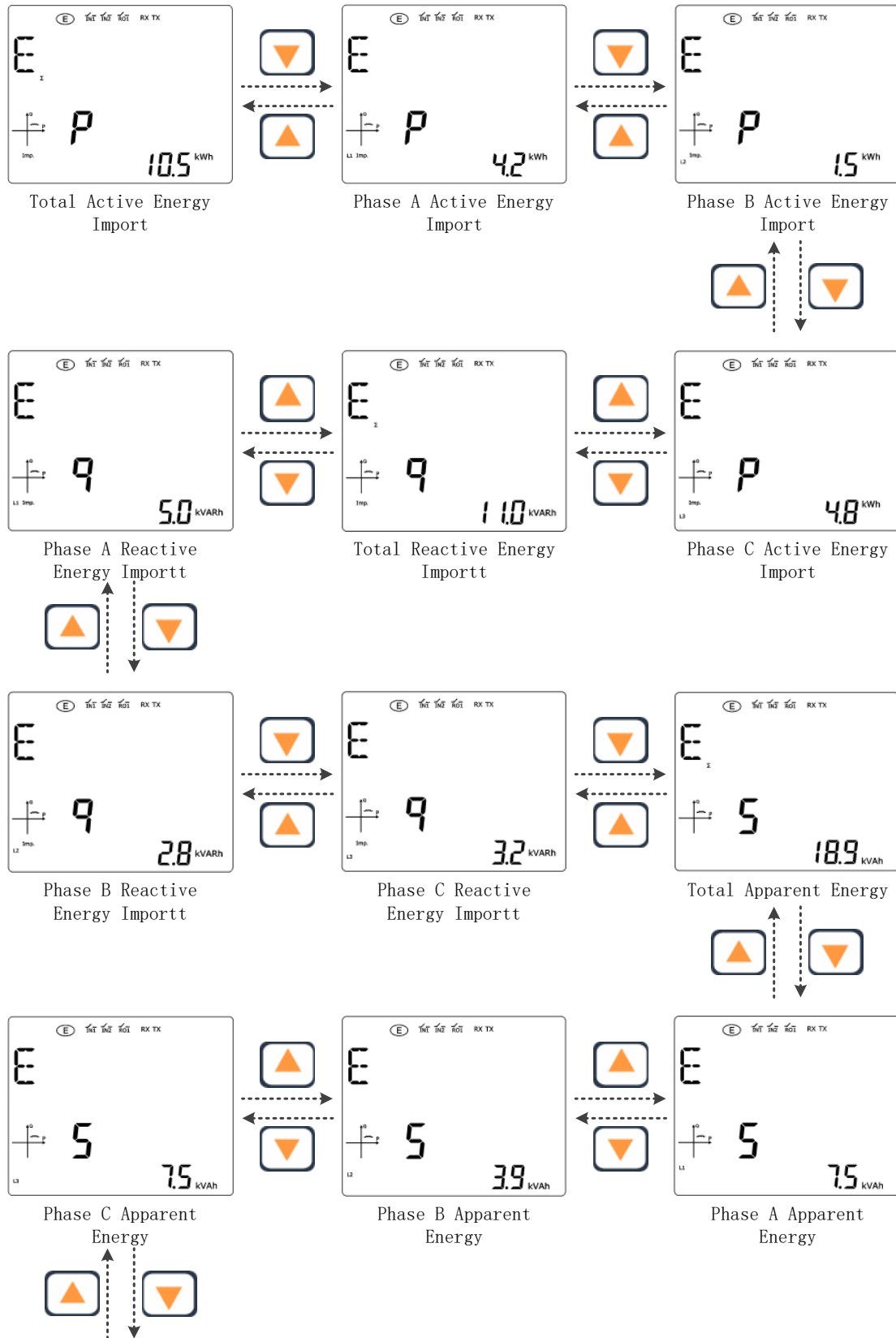

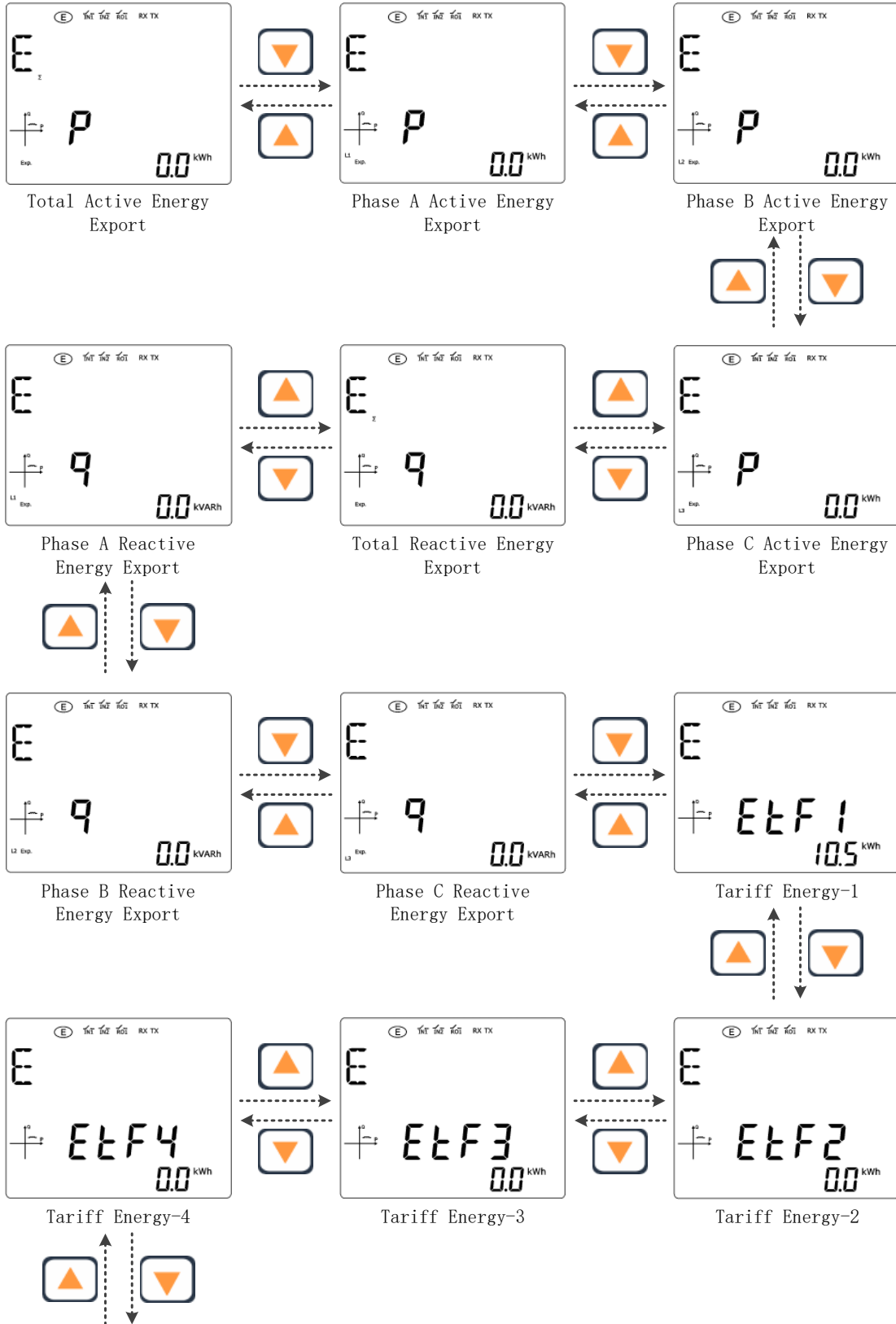

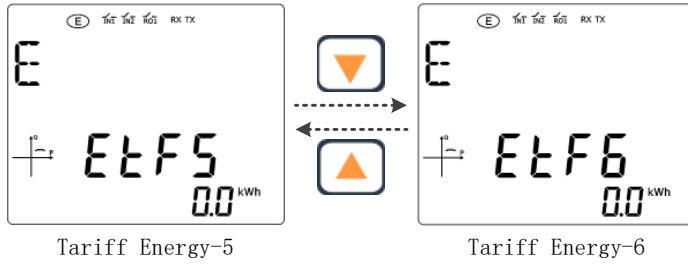

8.8.2 Energy Data Interface 3P3W

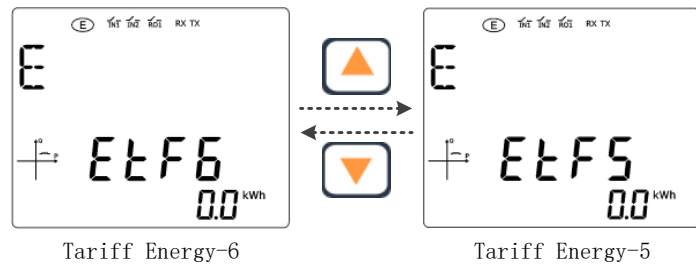
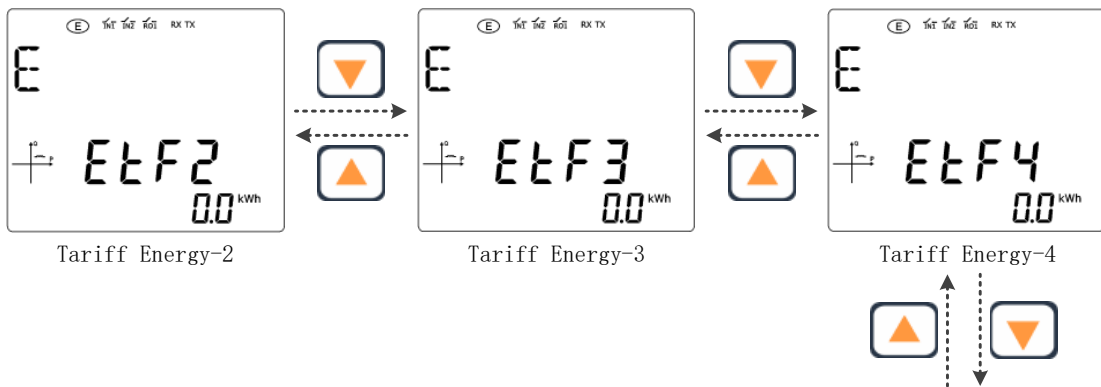
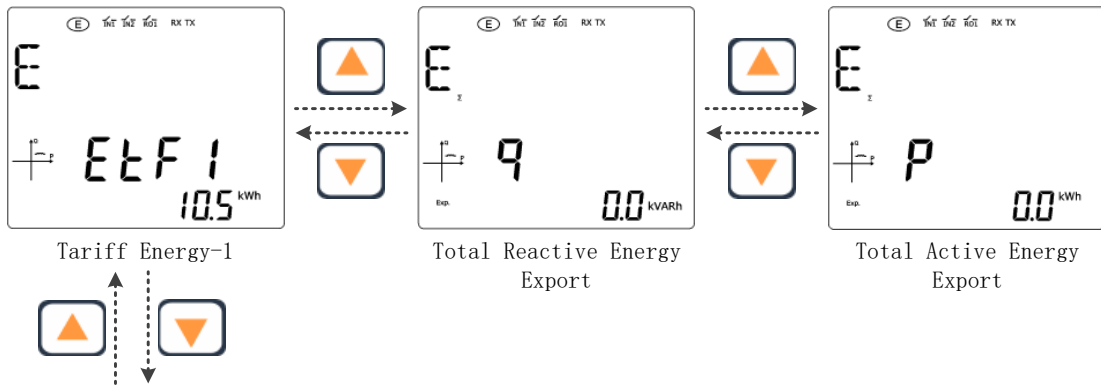
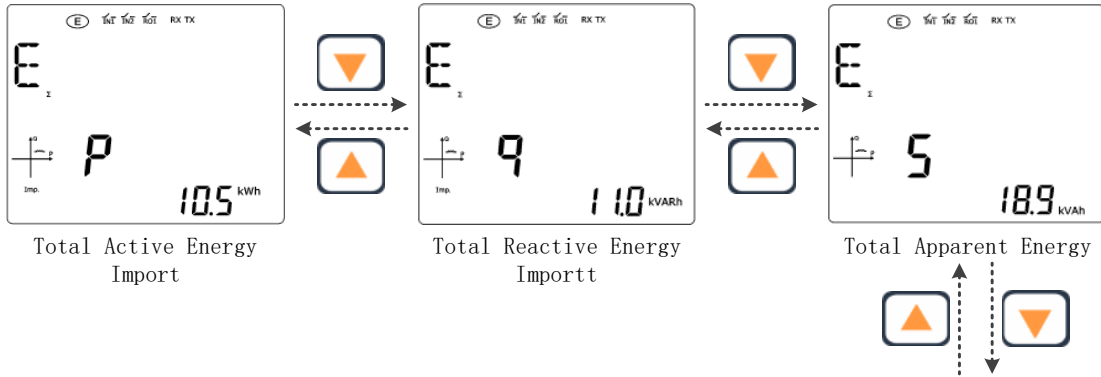

8.8.3 Energy Data Interface 1P3W

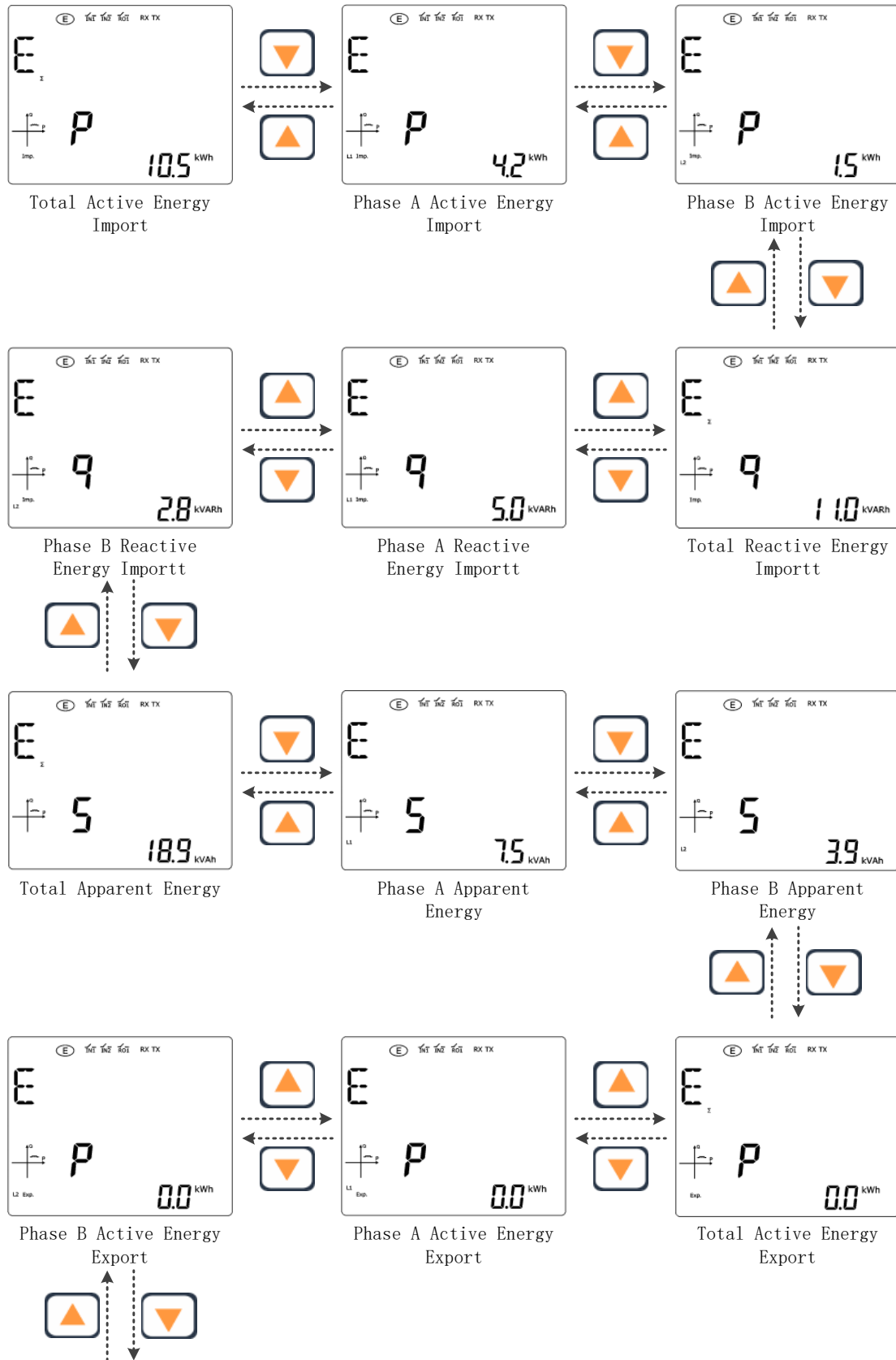

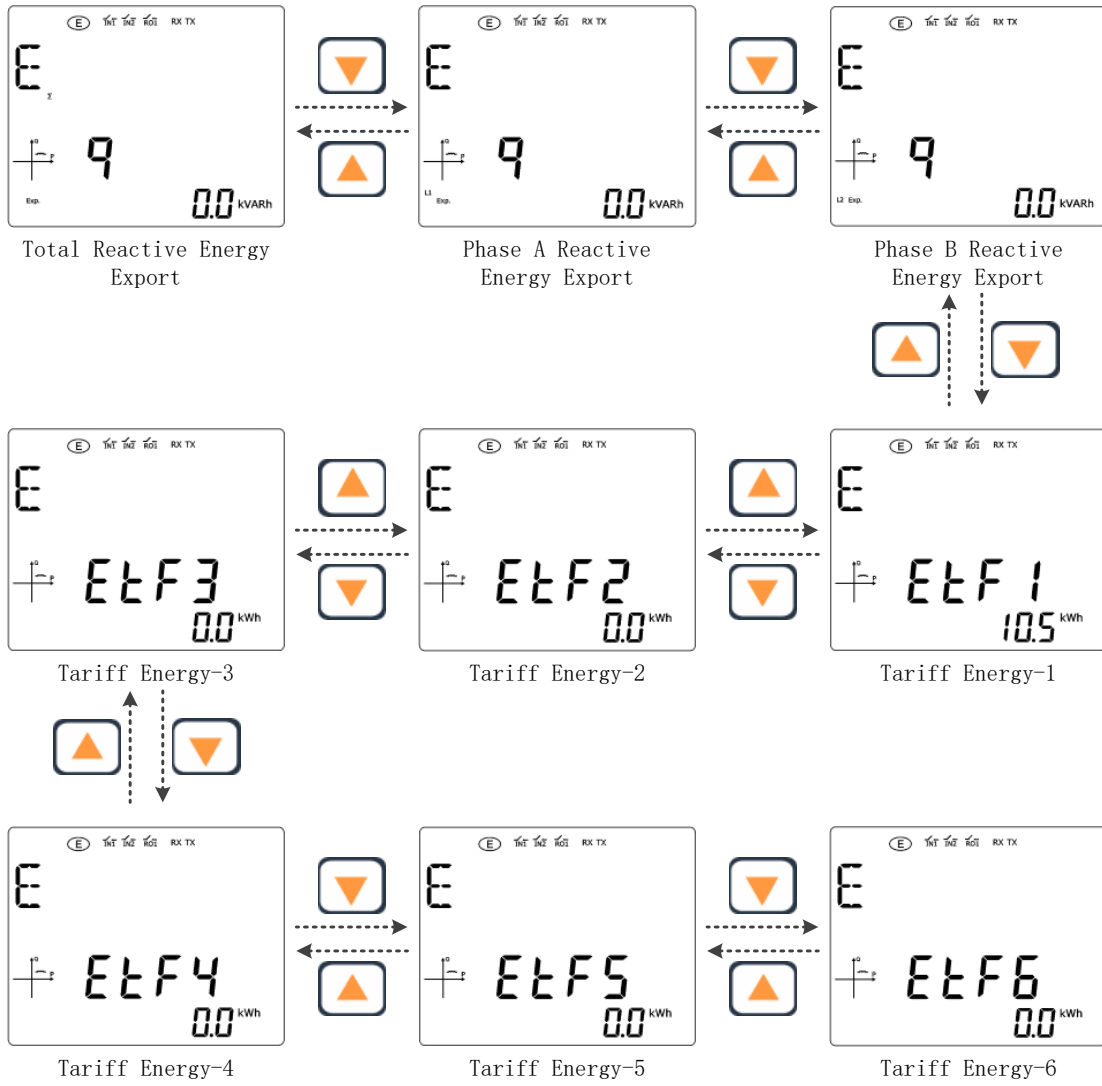

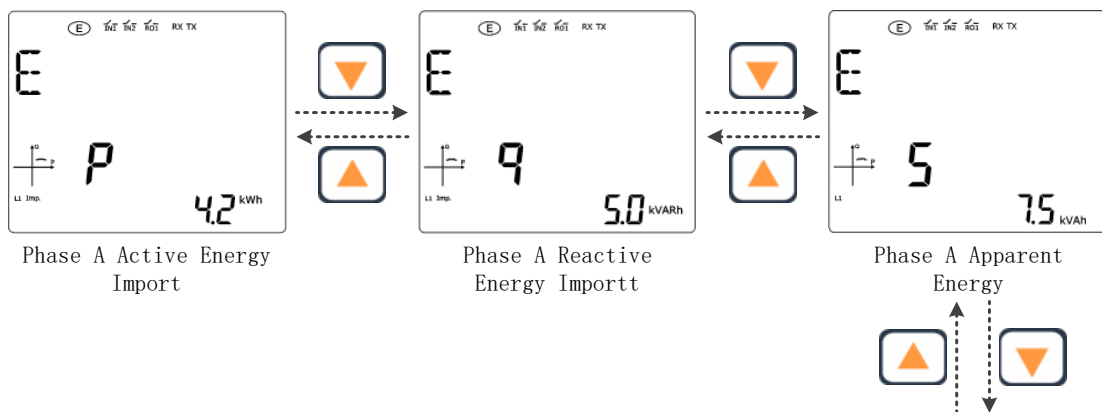

8.8.4 Energy Data Interface 1P2W

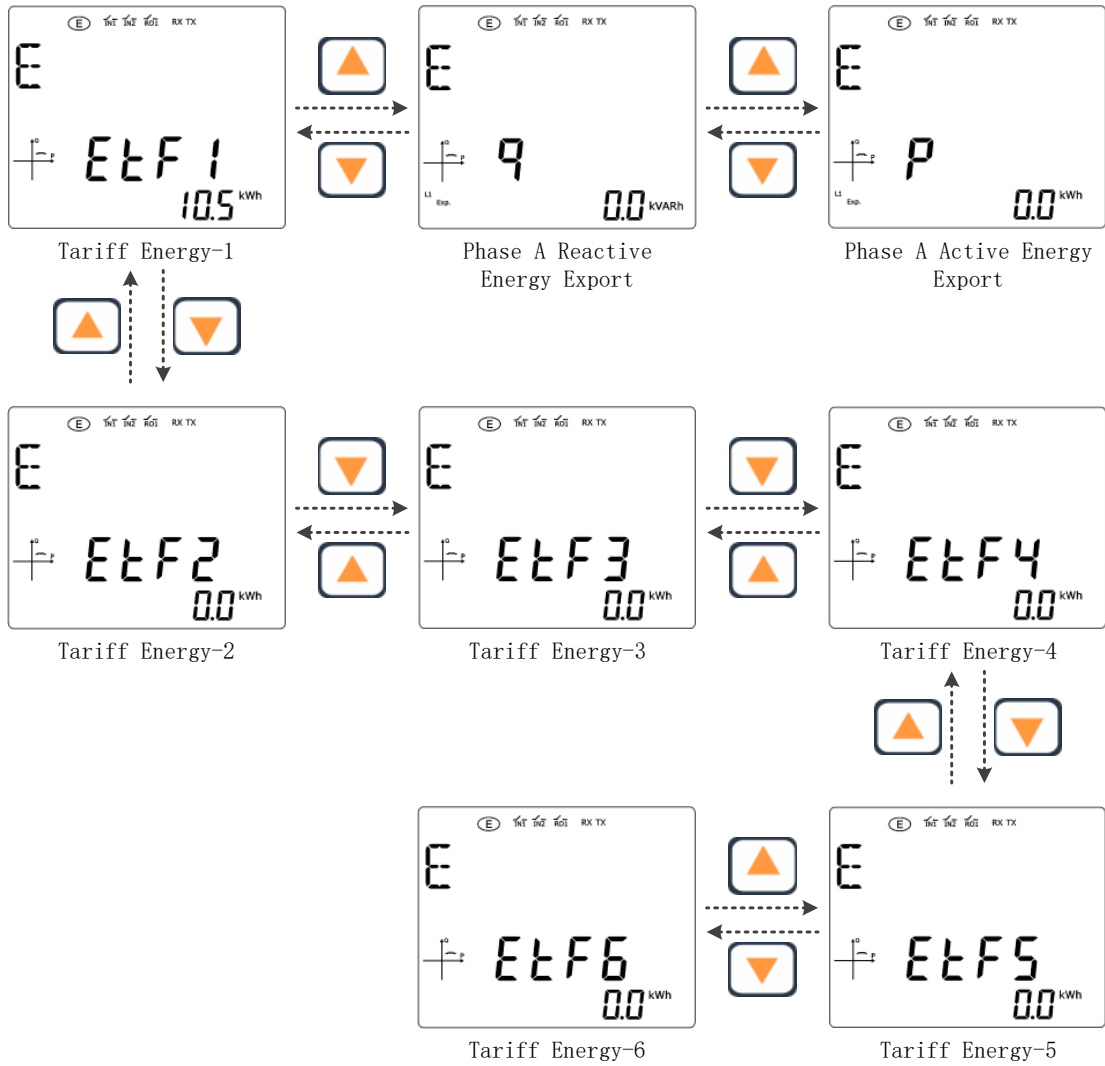



8.9 Device Information Interface

figure  display, indicating that the current mode is the device information display mode, the device information display interface is used to display: the current date, time, communication parameters, Energy pulse constant, equipment temperature and other data of the device. Use the  key or  key to toggle the display of the interface

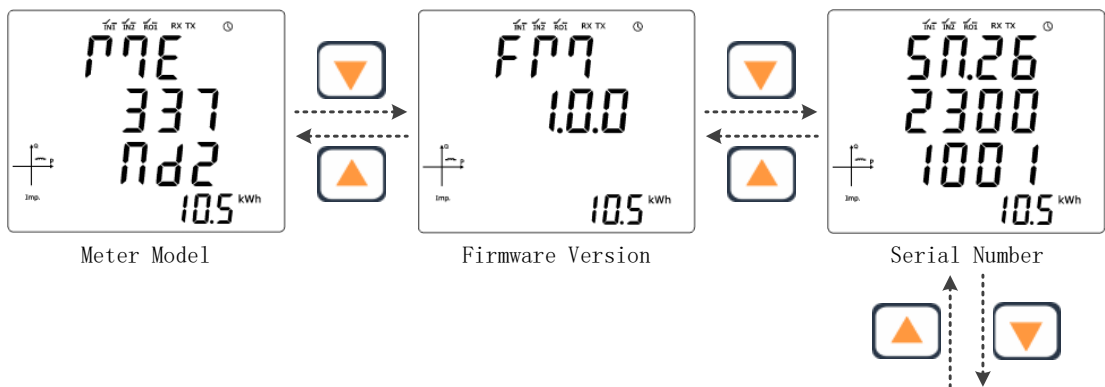

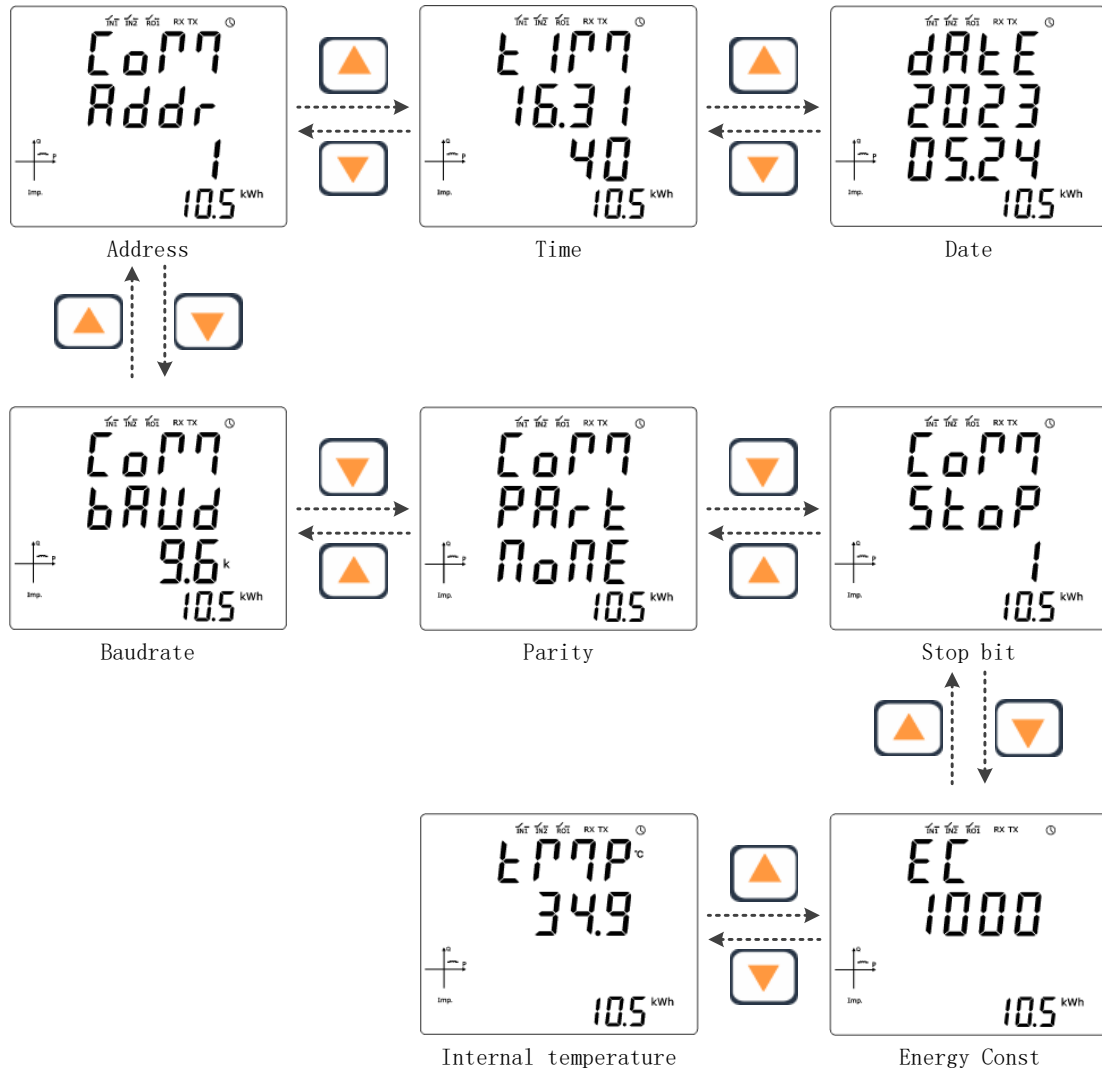

8.10 Device Configuration Interface

Figure PRG display, indicating that the current mode is the device configuration mode, the equipment configuration interface is used to configure: grid parameters, current transformer parameters, zero drift suppression, Tartar, demand, communication, relay, equipment, zero clearing and other parameters.

Before entering the configuration page, you need to enter the configuration password (default 1000), press the **ok** key to enter the password input, short press the **▲** key or **▼** key to modify the value size, long press the **▲** key or **▼** key





Input Password

to switch the value to be modified (the corresponding value will flash), press the **ok** key to confirm the password, if the password is correct will enter the configuration interface, if it is incorrect, continue to stay in the input password interface.

8.10.1 Configuration parameter selection

After entering the configuration page, there are 3 pages of configuration parameters to choose

from, short press the  key or  key to select the parameter to configure, press the  key to enter the corresponding parameter configuration page.



The meanings of each symbol are defined as follows:

symbol	meanings
gr Id	Configure grid parameters
CUr	Configure current transformer parameters
dr IF	Configure zero-drift suppression parameters
tAr 1	Configure Tariff parameter
dP7d	Configure demand parameters
CoP7	Configure communication parameters
rELy	Configure relay parameters
dEU	Configure device parameters
CLr	Clear

8.10.2 Configure grid parameters

On the Configure Parameters page, select *gr Id* to enter the grid parameter configuration interface.

The configurable parameters of the grid parameters interface are as follows:

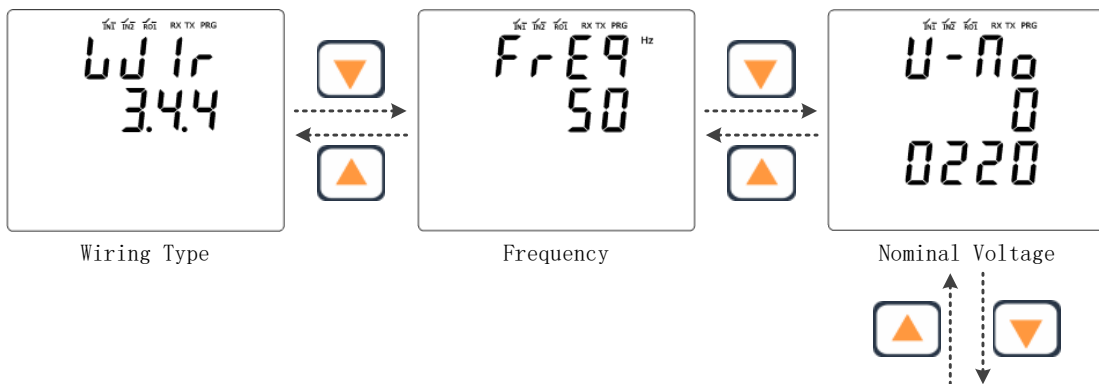

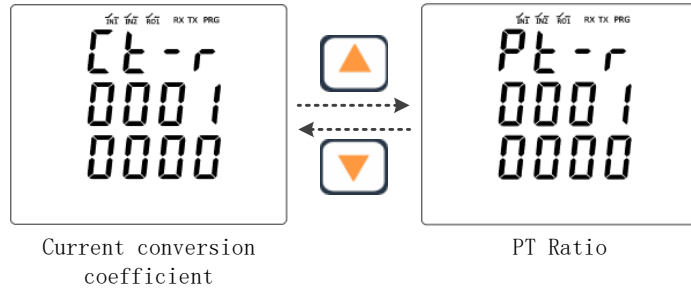

8.10.2.1 Configure the wiring type

This page is used to configure the wiring type of the device, which must be consistent with the actual wiring method of the meter.

Press the **ok** key to enter the setting, the corresponding value will flash, short press the key or key to modify the value size, long press the key or key to switch the value to be modified (the corresponding value will flash).

After the data modification is completed, press the **ok** key to confirm the data, there will be a prompt whether to save, short press the key or key, to select Yes or No, press the **ok** key again to perform the operation.



Wiring Type

The available wiring types:

symbol	meanings
3.4.4	Three-phase four-wire system 4CT, N-phase current is obtained by current transformer
3.4.3	The three-phase four-wire system 3CT, N-phase current is obtained by ABC three-phase current vector sum calculation
3.3.3	Three-phase three-wire system 3CT, B-phase current is obtained through a current transformer
3.3.2	Three-phase three-wire system 2CT, B phase current is obtained by AC phase current vector sum calculation
1.3	Single-phase three-wire system
1.2	Single-phase two-wire system

8.10.2.2 Configure grid frequency



This page is used to configure the nominal frequency of the grid, which must be consistent with the actual nominal frequency of the grid.

Press the **ok** key to enter the setting, the corresponding value will flash, short press the key or key to modify the value size, long press the key or key to switch the value to be modified (the corresponding value will flash).

After the data modification is completed, press the **ok** key to confirm the data, there will be a prompt whether to save, short



Frequency

press the  key or  key, to select Yes or No, press the  key again to perform the operation.





The available frequencies:





symbol	meanings
50	Select the nominal frequency of the grid 50Hz
60	Select the nominal frequency of the grid 60Hz

8.10.2.3 Configure nominal voltage

This page is used to configure the nominal voltage of the grid, which must be consistent with the actual nominal voltage of the grid.

➤ **The nominal voltage is used for zero drift suppression reference value.**

Press the  key to enter the setting, the corresponding value will flash, short press the  key or  key to modify the value size, long press the  key or  key to switch the value to be modified (the corresponding value will flash).

After the data modification is completed, press the  key to confirm the data, there will be a prompt whether to save, short press the  key or  key, to select Yes or No, press the  key again to perform the operation.











Nominal Voltage

8.10.2.4 Configure PT ratio

This page is used to configure the voltage transformer transformation ratio = (primary voltage / secondary voltage value) * 10000.unit V/V when the device voltage transformer is connected.

➤ **When there is no PT access, the value needs to be set to 10000**

Press the  key to enter the setting, the corresponding value will flash, short press the  key or  key to modify the value size, long press the  key or  key to switch the value to be modified (the corresponding value will flash).

After the data modification is completed, press the  key to confirm the data, there will be a prompt whether to save, short press the  key or  key, to select Yes or No, press the  key again to perform the operation.



PT Ratio

8.10.2.5 Configure current conversion factor

This page is used to configure the current conversion coefficient of the device, value = (actual conversion factor value) * 10000.

- When the conversion current value is not required, the value needs to be set to 10000
- The meter shows the current value = the measured current value * the conversion coefficient

Press the key to enter the setting, the corresponding value will flash, short press the key or key to modify the value size, long press the key or key to switch the value to be modified (the corresponding value will flash).

After the data modification is completed, press the key to confirm the data, there will be a prompt whether to save, short press the key or key, to select Yes or No, press the key again to perform the operation.



Current conversion coefficient

8.10.3 Configuring Current Transformer Parameters

Select **C_{U_r}** on the configuration parameters page to enter the current transformer parameter configuration interface.

The configurable parameters of the current transformer parameter interface are as follows:

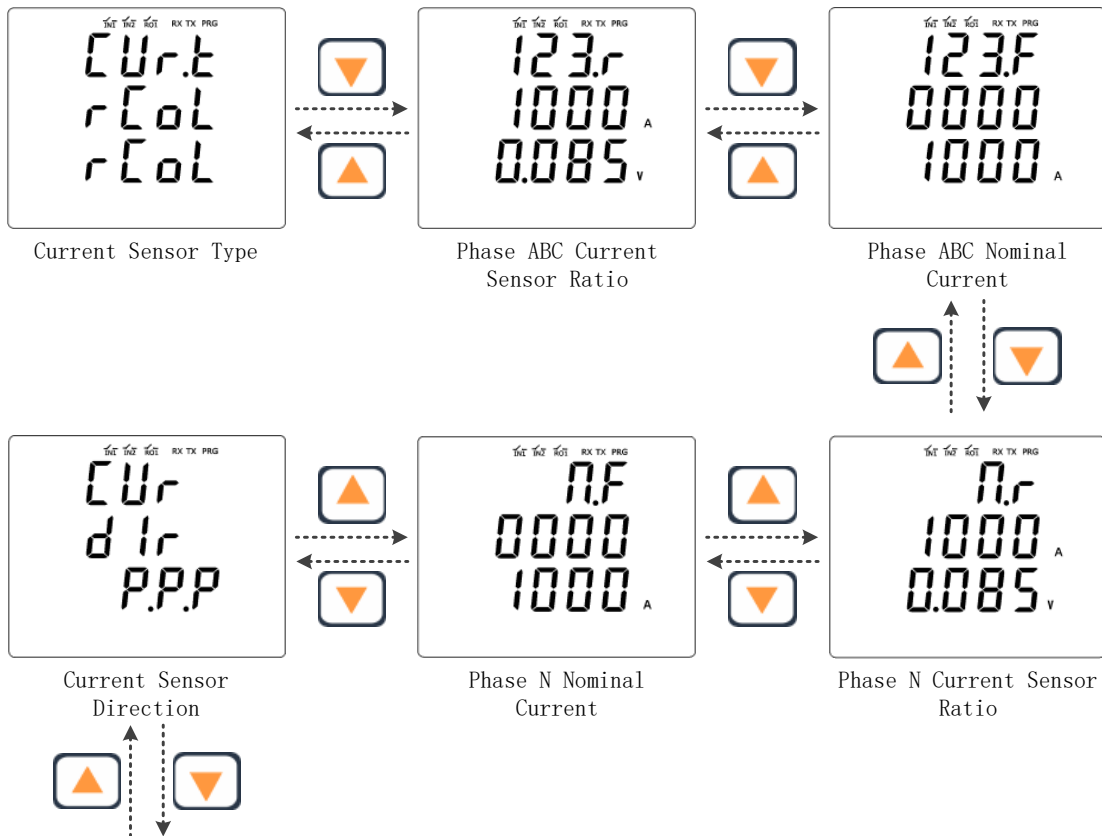



Current Sensor Channel

8.10.3.1 Configure the current transformer type

This page is used to configure the current transformer type.

- The second line of parameters shown is the ABC phase current transformer type
- The third line parameter shown is the N-phase current transformer type

Press the key to enter the setting, the corresponding value will flash, short press the key or key to modify the value size, long press the key or key to switch the value to be modified (the corresponding value will flash).

After the data modification is completed, press the key to confirm the data, there will be a prompt whether to save, short press the key or key, to select Yes or No, press the key again to perform the operation.

The available current transformers types:

symbol	meanings
rCoL	Configure the current transformer type to Rogowski coil
Uct	The current transformer type is configured to be a voltage output type CT



Current Sensor Type

8.10.3.2 Configure phase ABC current transformer ratio

This page is used to configure the ABC phase current transformer ratio.

- The second line of parameters displayed is the primary input current of current transformer
- The third line parameter displayed is the secondary output current of current transformer
- When the current transformer type is Rogowski coil, the output voltage value of the secondary terminal of the transformer needs to be set according to the nominal frequency.

Press the key to enter the setting, the corresponding value will flash, short press the key or key to modify the value size, long press the key or key to switch the value to be modified (the corresponding value will flash).

After the data modification is completed, press the key to confirm the data, there will be a prompt whether to save, short press the key or key, to select Yes or No, press the key again to perform the operation.



Phase ABC Current Sensor Ratio

8.10.3.3 Configure phase ABC nominal current

This page is used to configure the ABC phase nominal current, which needs to be set according to the maximum current measured.

Press the key to enter the setting, the corresponding value will flash, short press the key or key to modify the value size, long press the key or key to switch the value to be modified (the corresponding value will flash).

After the data modification is completed, press the key to confirm the data, there will be a prompt whether to save, short press the key or key, to select Yes or No, press the key again to perform the operation.



Phase ABC Nominal Current

8.10.3.4 Configure the N-phase current transformer ratio

This page is used to configure the N-current transformer ratio.

- **The second line of parameters displayed is the primary input current of current transformer**
- **The third line parameter displayed is the secondary output current of current transformer**
- **When the current transformer type is Rogowski coil, the output voltage value of the secondary terminal of the transformer needs to be set according to the nominal frequency.**



Phase N Current Sensor Ratio

Press the key to enter the setting, the corresponding value will flash, short press the key or key to modify the value size, long press the key or key to switch the value to be modified (the corresponding value will flash).

After the data modification is completed, press the key to confirm the data, there will be a prompt whether to save, short press the key or key, to select Yes or No, press the key again to perform the operation.

8.10.3.5 Configure the N-phase nominal current

This page is used to configure the N-phase nominal current, which is set according to the maximum current measured.

Press the key to enter the setting, the corresponding value will flash, short press the key or key to modify the value size, long press the key or key to switch the value to be modified (the corresponding value will flash).

After the data modification is completed, press the key to confirm the data, there will be a prompt whether to save, short press the key or key, to select Yes or No, press the key again to perform the operation.

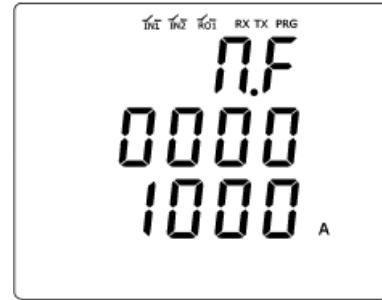

Phase N Nominal Current

8.10.3.6 Configure the ABC phase current transformer direction

This page is used to configure the ABC phase current transformer direction, when the current transformer direction is wrong or the current input terminal wiring is wrong, resulting in incorrect current direction, you can modify this parameter to correct the direction.

➤ **The first parameter of the third row displayed is the current direction of phase A, the second parameter is the current direction of phase B, and the third parameter is the current direction of phase C**

Press the key to enter the setting, the corresponding value will flash, short press the key or key to modify the value size, long press the key or key to switch the value to be modified (the corresponding value will flash).

After the data modification is completed, press the key to confirm the data, there will be a prompt whether to save, short press the key or key, to select Yes or No, press the key again to perform the operation.



Current Sensor Direction

The available configuration current transformer direction types:

symbol	meanings
P	Keep the original orientation of the current transformer unchanged
∩	Turn the current transformer inversely

8.10.3.7 Configure phase ABC current channel

This page is used to configure the ABC phase current channel, when the current channel and the voltage channel do not correspond, it will cause power calculation errors, at this time it is necessary to correct the correspondence between current and voltage, and the current and voltage can be modified by modifying this parameter.



Current Sensor Channel

- **The first parameter of the third line displayed is the phase corresponding to current channel 1, the second parameter is the phase corresponding to current channel 2, and the third parameter is the phase corresponding to current channel 3**
- **When the wiring is correct, channel 1 corresponds to phase A, channel 2 corresponds to phase B, and channel 3 corresponds to phase C**

Press the key to enter the setting, the corresponding value will flash, short press the key or key to modify the value size, long press the key or key to switch the value to be modified (the corresponding value will flash).

After the data modification is completed, press the key to confirm the data, there will be a prompt whether to save, short press the key or key, to select Yes or No, press the key again to perform the operation.

The available configuration current channel types:

symbol	meanings
A	Set the corresponding channel to phase A
b	Set the corresponding channel to phase B
C	Set the corresponding channel to phase C

8.10.4 Configuring Zero Drift Suppression Parameters

On the Configure Parameters page, select *dr IF* to enter the zero-drift suppression parameter configuration interface

The zero-drift rejection parameter configuration interface value is used to suppress voltage and current runout when there is no voltage and current input.

The parameters that can be configured on the zero-drift suppression parameter interface are as follows:

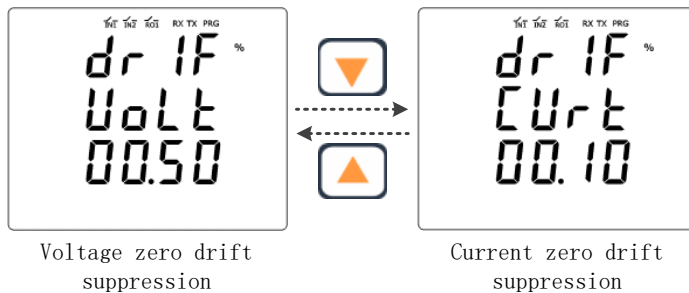

8.10.4.1 Configure voltage zero-drift suppression

This page is used to configure voltage zero drift suppression. When the voltage is lower than the set value, it is displayed as 0.

➤ **The reference value is the nominal voltage**

Press the key to enter the setting, the corresponding value will flash, short press the key or key to modify the value size, long press the key or key to switch the value to be modified (the corresponding value will flash).

After the data modification is completed, press the key to confirm the data, there will be a prompt whether to save, short press the key or key, to select Yes or No, press the key again to perform the operation.



Voltage zero drift suppression

8.10.4.2 Configure current zero drift suppression

This page is used to configure current zero drift suppression. When the current is below the set value, it is displayed as 0.

➤ **The reference value is the nominal current**

Press the key to enter the setting, the corresponding value will flash, short press the key or key to modify the value size, long press the key or key to switch the value to be modified (the corresponding value will flash).

After the data modification is completed, press the key to confirm the data, there will be a prompt whether to save, short press the key or key, to select Yes or No, press the key again to perform the operation.



Current zero drift suppression

8.10.5 Configure Tariff parameters

Select **tAr 1** on the configuration parameter page to enter the Tariff parameter configuration interface.

The Tariff parameter configuration interface values are used to set tariff control mode and select tariff.

- **The second line of parameters displayed is Tariff control mode, which can be controlled manually or RTC**
- **The parameter of the third line displayed is the manually selected current Tartar, which is not displayed when the Tariff control mode is RTC control mode.**



Tariff

Press the key to enter the setting, the corresponding value will flash, short press the key or key to modify the value size, long press the key or key to switch the value to be modified (the corresponding value will flash).

After the data modification is completed, press the key to confirm the data, there will be a prompt whether to save, short press the key or key, to select Yes or No, press the key again to perform the operation.

The available configuration Tariff control modes:

symbol	meanings
0000	The Tariff control mode is manual control mode, and Tariff can be selected through the interface or Modbus
010	The Tariff control mode is the RTC control mode, and the Tariff is automatically switched through the set time period. Tariff time period settings refer to the Modbus directive.

8.10.6 Configure Demand Parameters

On the Configure Parameters page, select 0000 to enter the Demand Parameter Configuration page.

The Demand parameter configuration interface value is used to set the demand calculation method and demand interval.

- The parameters in the second row displayed are the demand calculation method, which can be fixed or sliding.
- The parameters in line 3 shown are the demand calculation interval in minutes.



Demand

Press the key to enter the setting, the corresponding value will flash, short press the key or key to modify the value size, long press the key or key to switch the value to be modified (the corresponding value will flash).

After the data modification is completed, press the key to confirm the data, there will be a prompt whether to save, short press the key or key, to select Yes or No, press the key again to perform the operation.

The available demand calculation method:

symbol	meanings
F 1H	The demand calculation method is fixed
SL 1d	The demand calculation method is sliding

8.10.7 Configuring Communication Parameters

On the Configure Parameters page, select 0000 to enter the communication parameter configuration interface.

The configurable parameters of the Communication Parameters interface are as follows

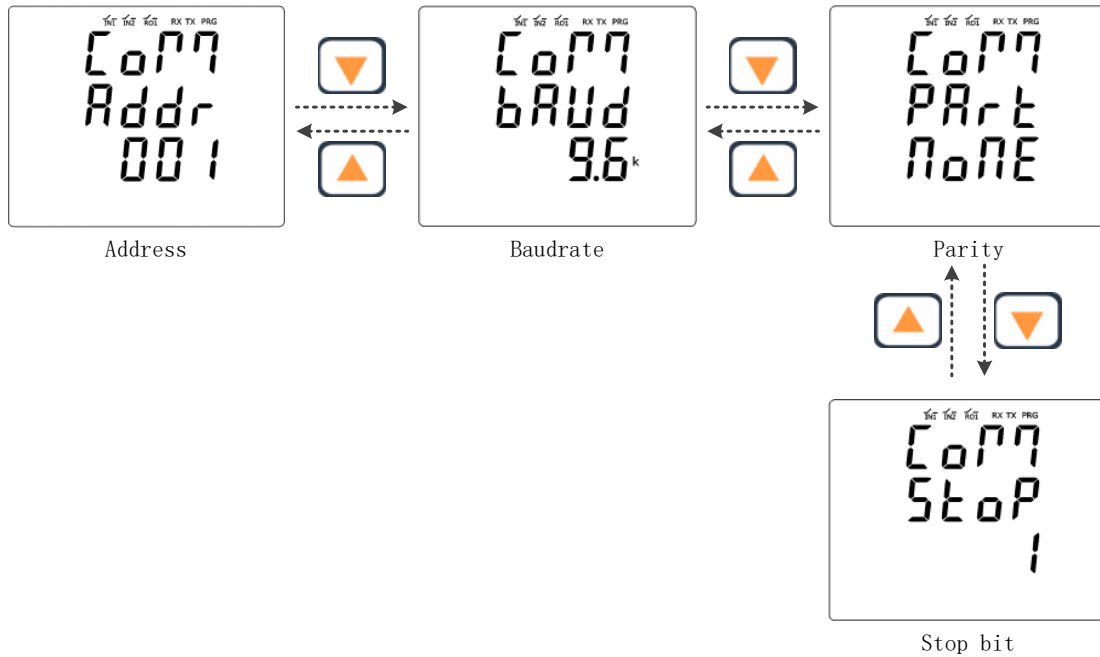

8.10.7.1 Configure the communication address

This page is used to configure communication addresses.

➤ **Configurable range: 1-247**

Press the **ok** key to enter the setting, the corresponding value will flash, short press the key or key to modify the value size, long press the key or key to switch the value to be modified (the corresponding value will flash).

After the data modification is completed, press the **ok** key to confirm the data, there will be a prompt whether to save, short press the key or key, to select Yes or No, press the **ok** key again to perform the operation.



Address

8.10.7.2 Configure communication Baud

This page is used to configure the communication baud.

Press the **ok** key to enter the setting, the corresponding value will flash, short press the key or key to modify the value size, long press the key or key to switch the value to be modified (the corresponding value will flash).

After the data modification is completed, press the **ok** key to confirm the data, there will be a prompt whether to save, short press the key or key, to select Yes or No, press the **ok** key again to perform the operation.



Baudrate

The available configured communication Baud types:

symbol	meanings
2.4 ^k	Set the communication baud to 2400bps

4.8 ^k	Set the communication baud to 4800bps
9.6 ^k	Set the communication baud to 9600bps
19.2 ^k	Set the communication baud to 19200bps
38.4 ^k	Set the communication baud to 38400bps
57.6 ^k	Set the communication baud to 57600bps
115.2 ^k	Set the communication baud to 115200bps

8.10.7.3 Configure communication parity

This page is used to configure communication parity.

Press the key to enter the setting, the corresponding value will flash, short press the key or key to modify the value size, long press the key or key to switch the value to be modified (the corresponding value will flash).

After the data modification is completed, press the key to confirm the data, there will be a prompt whether to save, short press the key or key, to select Yes or No, press the key again to perform the operation.

The available configuration parity types:

symbol	meanings
<i>NONE</i>	Set communication parity to NONE
<i>odd</i>	Set communication parity to ODD
<i>EVEN</i>	Set communication parity to EVEN



Parity

8.10.7.4 Configure communication stop bits

This page is used to configure communication stop bits.

➤ **Configurable values are: 1 or 2**

Press the key to enter the setting, the corresponding value will flash, short press the key or key to modify the value size, long press the key or key to switch the value to be modified (the corresponding value will flash).

After the data modification is completed, press the key to confirm the data, there will be a prompt whether to save, short press the key or key, to select Yes or No, press the key again to perform the operation.



Stop bit

8.10.8 Configure relay parameters

Select **rELY** on the configuration parameter page to enter the relay parameter configuration interface.

The relay parameter configuration interface values are used to set the control mode and output of the relay.

- **The second line parameter displayed is the relay control mode, which can be manually controlled or alarm output controlled.**
- **The third line parameter displayed is the current relay output for manual control. When the relay control mode is alarm output control mode, this line is not displayed.**



Relay

Press the **ok** key to enter the setting, the corresponding value will flash, short press the **▲** key or **▼** key to modify the value size, long press the **▲** key or **▼** key to switch the value to be modified (the corresponding value will flash).

After the data modification is completed, press the **ok** key to confirm the data, there will be a prompt whether to save, short press the **▲** key or **▼** key, to select Yes or No, press the **ok** key again to perform the operation.

The available relay control methods:

symbol	meanings
nnnn	The relay control method is manual control, and the relay output can be controlled through the operation interface or Modbus
ALPn	The relay control method is alarm output control. When there is a parameter alarm, the relay outputs. For specific alarm parameter settings, refer to Modbus

The available manual control relay output values:

symbol	meanings
oPEN	Relay output open
CLoS	Relay output closed

8.10.9 Configuring device parameters

Select **dEU** on the configuration parameter page to enter the device parameter configuration interface.

The configurable parameters of the device parameter interface are as follows:

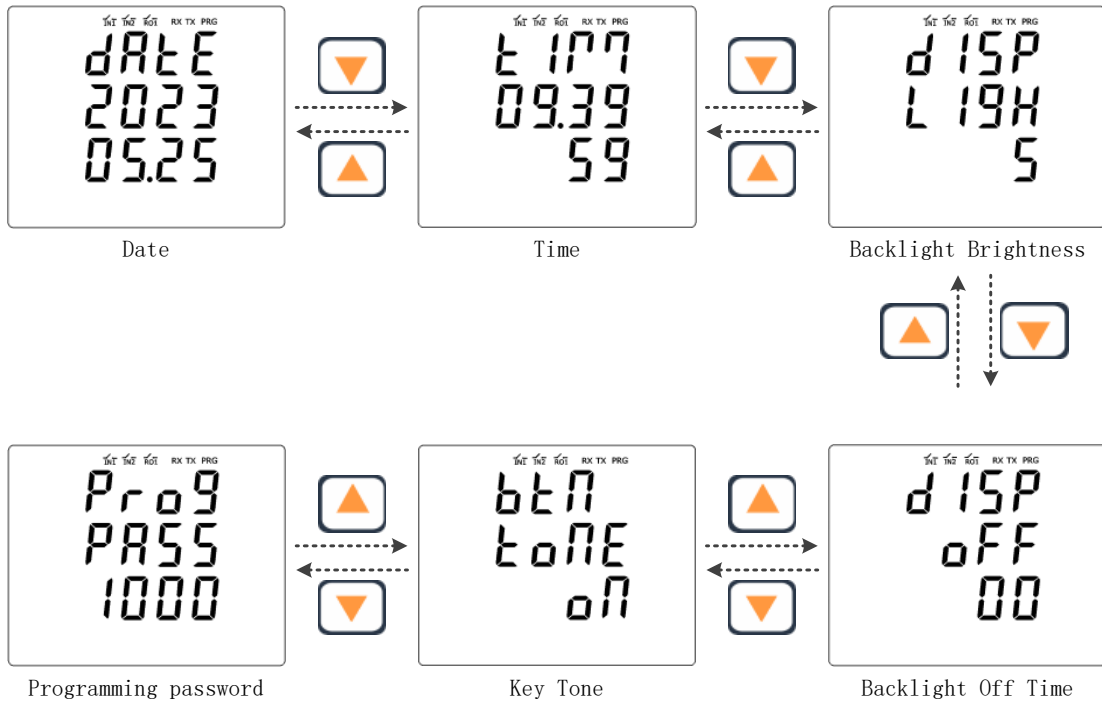

8.10.9.1 Configure device date

This page is used to configure device date.

Press the **ok** key to enter the setting, the corresponding value will flash, short press the key or key to modify the value size, long press the key or key to switch the value to be modified (the corresponding value will flash).

After the data modification is completed, press the **ok** key to confirm the data, there will be a prompt whether to save, short press the key or key, to select Yes or No, press the **ok** key again to perform the operation.



Date

8.10.9.2 Configure device time

This page is used to configure device time.

Press the **ok** key to enter the setting, the corresponding value will flash, short press the key or key to modify the value size, long press the key or key to switch the value to be modified (the corresponding value will flash).

After the data modification is completed, press the **ok** key to confirm the data, there will be a prompt whether to save, short press the key or key, to select Yes or No, press the **ok** key again to perform the operation.



Time

8.10.9.3 Configure device backlight brightness

This page is used to configure the device backlight brightness.

➤ **Configurable range: 1-5**

Press the key to enter the setting, the corresponding value will flash, short press the key or key to modify the value size, long press the key or key to switch the value to be modified (the corresponding value will flash).

After the data modification is completed, press the key to confirm the data, there will be a prompt whether to save, short press the key or key, to select Yes or No, press the key again to perform the operation.



Backlight Brightness

8.10.9.4 Configure the device backlight off time

This page is used to configure the device backlight off time. If no keys are detected within the set time, the backlight turns off.

➤ **Configurable range: 0-99 minute**

When the backlight off time is 0, it means that the backlight is always on

Press the key to enter the setting, the corresponding value will flash, short press the key or key to modify the value size, long press the key or key to switch the value to be modified (the corresponding value will flash).

After the data modification is completed, press the key to confirm the data, there will be a prompt whether to save, short press the key or key, to select Yes or No, press the key again to perform the operation.



Backlight Off Time

8.10.9.5 Configure the device key tone

This page is used to configure the device key tone. When the device key tone is on, pressing the key, buzzer will sound.

Press the key to enter the setting, the corresponding value will flash, short press the key or key to modify the value size, long press the key or key to switch the value to be modified (the corresponding value will flash).

After the data modification is completed, press the key to confirm the data, there will be a prompt whether to save, short press the key or key, to select Yes or No, press the key again to perform the operation.

The available key tone control methods:



Key Tone

symbol	meanings
on	The key tone is turned on, press the key, and the buzzer will sound
off	The key tone is off, press the key, and the buzzer will not sound

8.10.9.6 Configure the device programming password

This page is used to configure the device programming password.

➤ **Default programming password: 1000**

Press the key to enter the setting, the corresponding value will flash, short press the key or key to modify the value size, long press the key or key to switch the value to be modified (the corresponding value will flash).

After the data modification is completed, press the key to confirm the data, there will be a prompt whether to save, short press the key or key, to select Yes or No, press the key again to perform the operation.



Programming password

8.10.10 Configure the clear parameter

On the Configure Parameters page, select **Clr** to enter the zeroing parameter configuration interface.

The clear parameter configuration interface is used to clear parameters such as zero maximum value, demand, Tariff Energy, and Energy.

Press the key to enter the setting, the corresponding value will flash, short press the key or key to modify the value size, long press the key or key to switch the value to be modified (the corresponding value will flash).

After the data modification is completed, press the key to confirm the data, there will be a prompt whether to save, short press the key or key, to select Yes or No, press the key again to perform the operation.

The available configuration clear types:



Clear

symbol	meanings
EtrE	Clear the maximum and minimum values
drrd	Clear demand
tAr 1	Clear Tariff Energy
ENgy	Clear Energy
ALL	Clear the maximum and minimum values, demand, Tariff Energy, Energy

9. Modbus Communication

Communication	
Communication port	RS485
Communication protocol	Modbus RTU

ME337 adopts the standard Modbus RTU protocol.

9.1 Modbus Communication settings

Before performing the Modbus-RTU communication, the following parameters need to be set through the interface of the meter:

Parameter	Effective value	Default value
Address	1–247	1
Baud rate	-1200 -2400 -4800 -9600 -19200 -38400 -57600 -115200	9600
Data bits	8	8
Parity check	– None – Odd – Even	None
Stop bit	1-2	1

9.2 Modbus-RTU data frame

Modbus RTU data frame includes 4 parts: Address field, Function code, Data and CRC Check.

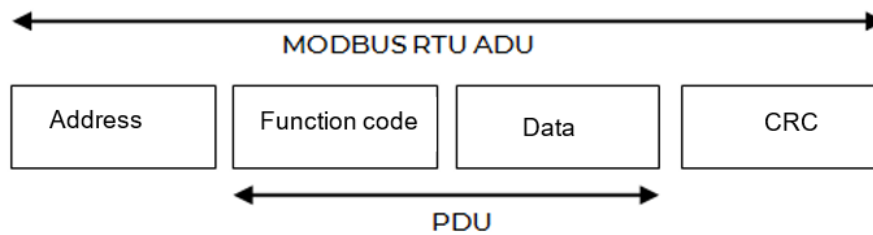

9.3 PDU Request data Format

Function code	Data
8-Bits	Nx8-Bits

9.4 Function code

Function codes are used to indicate how the analyzer processes the instruction. The following table shows the available function codes and their descriptions.

Function code		Name of function code	Function	Remarks
Decimal	Hexadecimal			
3	03H	Read holding register	Used to read meter's parameters	
16	10H	Write multiple registers	Used to configure meter parameters	

9.5 Register Description

The register list has the following entries:

Register name	Register address	operation Read / write	register number	type	Unit	description
---------------	------------------	---------------------------	--------------------	------	------	-------------

- **Register name:** used to indicate the purpose of the register.
- **Register address:** the address of Modbus register in Decimal.
- **Operation:** used to indicate the operation that the register can perform.
- **Number of registers:** indicates how many int16 sizes the register has.
- **Type:** describes the type of data
- **Unit:** indicates the size of the register value unit
- **Description:** a description of the register

9.6 Data type list

The following table lists the data types used in this document:

Type	description	Range
UInt16	16 bit unsigned integer	0–65535
Int16	16 bit signed integer	-32768–+32767
UInt32	32 bit unsigned integer	0–4 294 967 295
UInt64	64 bit unsigned integer	0–18 446 744 073 709 551 615
UTF8	8-bit UTF	Multibyte unicode coding
Float32	32-bit floating point number	Standard IEEE single precision floating point numbers
Date Time	Date and Time Types	-
Time	Time Type	-

Date Time format:

Byte	Position														
	15	14	13	12	11	10	9	8	7	6	5	4	3	2	1
1	Year(2000–2099)														
2	Month (1–12)							Day (1–31)							
3	Hour (0–23)							Second (0–59)							
4	Millisecond (0–59)														

Time format:

Byte	Position														
	15	14	13	12	11	10	9	8	7	6	5	4	3	2	1
1	Hour (0–23)														
2	Second (0–59)														
3	Millisecond (0–59)														

Configure the device via the Modbus-RTU

You can use the function code 16 to write instructions to the device and configure the device parameters.

The device parameter configuration can only be configured by writing the corresponding data to the "configuring instruction register", that is, writing the corresponding data to the address starting from 300 to configure the corresponding parameters.

9.7 Configuration results

The configuration results can be obtained by reading registers 424 and 425.

Register address	Description	Size (UInt16)	Data (example)
424	Configuration instruction code	1	1001(set Date Time)
425	Configuration results	1	0 = configuration successful 80 = invalid instruction code 81 = invalid parameter value 82 = number of invalid parameters 83 = instruction not executed

9.8 Modbus-RTU Function code

9.8.1 Function code (0x10=16) Operation Instructions

Function code(0x10=16) is used to configure the parameters of the device, and its request and return instructions are defined as follows:

Configuration device parameter command format:

No.	Meaning	Type	Range (Decimal)	Description
1	Device address	UInt8	1-247	
2	Function code	UInt8	16	
3	Register start address	UInt16	-	High byte first(sending sequence)
4	Number of configuration registers	UInt16	1-123	High byte first(sending sequence)
5	Data length	UInt8		Number of configuration registers * 2
6	First register configuration data	UInt16	-	High byte first(sending sequence)
7	...	UInt16	-	High byte first(sending sequence)
8	nth register configuration data	UInt16	-	High byte first(sending sequence)
9	CRC-16 parity code	UInt16	-	low byte first(sending sequence)

Return to configuration device parameter command format:

No.	Meaning	Type	Range (Decimal)	Description
1	Device address	UInt8	1-247	

No.	Meaning	Type	Range (Decimal)	Description
2	Function code	UInt8	16	
3	Register start address	UInt16	300	High byte first
4	Number of configuration registers	UInt16	1-123	High byte first
5	CRC-16 parity code	UInt16	-	low byte first



Attention

The function code (0x10=16) can only write data to the "configuration instruction register", that is, it can only write data to the register starting from address 300.

For example:

Configure the analyzer time (command =1200, set to: 2022-11-1 12:20:00)

No.	Name	Type	Value (Decimal)	Value (HEX)	Description
1	Device address	UInt8	1	01	
2	Function code	UInt8	16	10	
3	Data byte length	UInt16	300	012C	Configuration register start address
4	Number of read registers	UInt16	7	0007	Configure Time Command + parameter total 7 registers are occupied
5	Data length	UInt8	14	0E	Number of configuration registers * 2
6	Register 300 write value	UInt16	1200	04B0	Instruction code 1200 to configure time
7	Register 301 write value	UInt16	2022	07E6	Year of configuration time = 2022
8	Register 302 write value	UInt16	11	000B	Month of configuration time = 11
9	Register 303 write value	UInt16	1	0001	Day of configuration time = 1
10	Register 304 write value	UInt16	12	000C	Time of configuration = 12
11	Register 305 write value	UInt16	20	0014	Minutes of configuration time =20
12	Register 306 write value	UInt16	0	0000	Seconds of configuration time = 0
13	CRC-16 parity code	UInt16	35524	8AC4	low byte first(sending sequence)

The order of sending bytes is as follows:

01 10 01 2C 00 07 0E 04 B0 07 E6 00 0B 00 01 00 0C 00 14 00 00 C4 8A

After the configuration is successful, the received data packets are as follows:

01 10 01 2C 00 07 41 FE

No.	Meaning	Type	Value (decimal)	Value (HEX)
1	Device address	UInt8	01	1
2	Function code	UInt8	10	16
3	Register start address	UInt16	012C	300
4	Number of configuration registers	UInt16	0007	7
5	CRC-16 parity code	UInt16	41FE	

9.8.2 Function code (0x03=3) operation instructions

The function code (0x03=3) is used to read the parameters of the analyzer register. Its request data and return data format are as follows:

Request data format:

No.	Name	Type	Range (Decimal)	Description
1	Device address	UInt8	1-247	
2	Function code	UInt8	3	
3	Register start address	UInt16	-	High byte first(sending sequence)
4	Number of read registers	UInt16	1-125	High byte first(sending sequence)
5	CRC-16 parity code	UInt16	-	low byte first(sending sequence)

Return data format:

No.	Name	Type	Range (Decimal)	Description
1	Device address	UInt8	1-247	
2	Function code	UInt8	3	
3	Data byte length	UInt8	-	Number of registers * 2
4	1st register data		-	High byte first
5	...		-	High byte first
6	nth register data		-	High byte first
7	CRC-16 parity code	UInt16	-	Low byte first

Example of reading device parameters:

Read the voltage values of L1, L2 and L3 (the starting address of the voltage register is 1010):

No.	Name	Type	Range (Decimal)	Range (HEX)	Description
1	Device address	UInt8	1	0x01	
2	Function code	UInt8	3	0x03	
3	Register start address	UInt16	1010	0x03F2	
4	Number of read registers	UInt16	6	0x0006	

No.	Name	Type	Range (Decimal)	Range (HEX)	Description
5	CRC-16 parity code	UInt16	32612	0x7F64	low byte first(sending sequence)

The order of sending hexadecimal bytes is as follows:

01 03 03 F2 00 06 64 7F

The received packets are as follows:

01 03 0C 43 5C 00 00 43 5D 00 00 43 5E 00 00 14 AC

No.	Name	Type	Hexadecimal	Decimal
1	Device address	UInt8	01	1
2	Function code	UInt8	03	3
3	Data byte length	UInt8	0C	12
4	Address 2147 data (phase a voltage)	float32	435C0000	220V
5	Address 2148 data (phase B voltage)	float32	435D0000	221V
6	Address 2149 data (phase C voltage)	float32	435E0000	222V
7	CRC-16 parity code	UInt16	14AC	

9.8.3 Error response

Error response data format:

No.	Name	Type	Decimal	Hexadecimal	Description
1	Device address	UInt8	1-247	0x01-0xF7	
2	Function code	UInt8	(128+3) (128+16)	(0x80+0x03) (0x80+0x10)	
3	Error code	UInt8			
4	CRC-16 parity code	UInt16			low byte first(sending sequence)

Modbus Error code:

Code (HEX)	Name	Meaning
0x01	Illegal function code	The function code supported by the analyzer is not used.
0x02	Illegal data address	The register data written or read is not a supported address range.
0x03	Illegal data value	The data value written to the register does not meet the requirements.
0x04	Analyzer error	An unknown error occurred

9.9 List of configuration instructions

9.9.1 System parameter setting

Instruction code	Operation	Size	Type	Unit	Range (Decimal)	Description
1001	W	1	UInt16	-	0,1,2,3,4,5	Wiring mode 0=3P4W_4CT 1=3P4W_3CT 2=3P3W_3CT 3=3P3W_2CT 4=1P3W 5=1P2W
	W	1	UInt16	Hz	50,60	Grid frequency
	W	1	UInt16	V	1-65535	Nominal voltage (not including VT ratio)
	W	2	UInt32	-	1-99999999	VT ratio, 10000 times magnification
	W	2	UInt32	-	1-99999999	CT ratio, 10000 times magnification

9.9.2 Parameter setting of L1,L2,L3 current transformer

Instruction code	Operation	Size	Type	Unit	Range (Decimal)	Description
1002	W	1	UInt16	-	0,1	Phase L1L2L3 current sensor type 0 = Rogowski coil 1 = VCT
	W	2	UInt32	A	1-999999	Phase L1L2L3 Rogowski coil input
	W	2	UInt32	mV@50 Hz mV@60 Hz	1-9999	Phase L1L2L3 Rogowski coil output (Note: The output should be set according to the set power grid frequency)
	W	2	UInt32	A	1-999999	Phase L1L2L3 Rogowski coil Nominal Current
	W	2	UInt32	A	1-999999	Phase L1L2L3 VCT input
	W	2	UInt32	mV	1-9999	Phase L1L2L3 VCT output
	W	2	UInt32	A	1-999999	Phase L1L2L3 VCT nominal current

9.9.3 Parameter setting of N-phase current transformer

Instruction code	Operation	Size	Type	Unit	Range (Decimal)	Description
1003	W	1	UInt16	-	0,1	Phase N current sensor type 0 = Rogowski coil 1 = VCT
	W	2	UInt32	A	1-999999	Phase N Rogowski coil input
	W	2	UInt32	mV@50 Hz mV@60 Hz	1-9999	Phase N Rogowski coil output (Note: The output should be set according to the set power grid frequency)
	W	2	UInt32	A	1-999999	Phase N Rogowski coil Nominal Current
	W	2	UInt32	A	1-999999	Phase N VCT input
	W	2	UInt32	mV	1-9999	Phase N VCT output
	W	2	UInt32	A	1-999999	Phase N VCT nominal current

9.9.4 Current Sensor Direction setting

When the coil direction is inconsistent with the actual situation, this configuration can be used to modify the current direction

Instruction code	Operation	Size	Type	Unit	Range (Decimal)	Description
1010	W	1	UInt16	-	0,1	Phase A Current Sensor Direction 0=Positive (Default) 1=Negative
	W	1	UInt16	-	0,1	Phase B Current Sensor Direction 0=Positive (Default) 1=Negative
	W	1	UInt16	-	0,1	Phase C Current Sensor Direction 0=Positive (Default) 1=Negative

9.9.5 Current Sensor Channel setting

When the current and voltage do not correspond, this configuration can be used to modify the current channel selection so that the current and voltage correspond to each other

Instruction code	Operation	Size	Type	Unit	Range (Decimal)	Description
1011	W	1	UInt16	-	0,1,2	Phase A Current Sensor Channel 0=channel 1 (Default) 1=channel 2 2=channel 3
	W	1	UInt16	-	0,1,2	Phase B Current Sensor Channel 0=channel 1 1=channel 2 (Default) 2=channel 3
	W	1	UInt16	-	0,1,2	Phase C Current Sensor Channel 0=channel 1 1=channel 2 2=channel 3 (Default)

9.9.6 Zero drift suppression setting

Instruction code	Operation	Size	Type	Unit	Range (Decimal)	Description
1020	W	1	UInt16	%	0~1000	Voltage zero drift suppression Take (nominal voltage * VT variable ratio) as a reference = Actual value * 100 Default: 10
	W	1	UInt16	%	0~1000	Current zero drift suppression With (nominal current * CT change ratio) as a reference = Actual value * 100 Default: 10

9.9.7 Demand parameter setting

Instruction code	Operation	Size	Type	Unit	Range (Decimal)	Description
1060	W	1	UInt16	-	0,1	Demand calculation method 0= fixed 1= sliding type
	W	1	UInt16	minute	1-60	Demand calculation interval

9.9.8 Tariff mode setting

Instruction code	Operation	Size	Type	Unit	Range (Decimal)	Description
1070	W	1	UInt16	-	0,1	Switch mode 0 = Manual 1 = RTC

9.9.9 Manual tariff setting

Instruction code	Operation	Size	Type	Unit	Range (Decimal)	Description
1071	W	1	UInt16	-	0-5	Manual tariff setting 0 = Tariff select 1 1 = Tariff select 2 ... 5 = Tariff select 6 (Note: This setting is only valid if the tariff mode is manual switching)

9.9.10 RTC tariff period setting

Instruction code	Operation	Size	Type	Unit	Range (Decimal)	Description
1072	W	3	Time	-	-	Ta Start
	W	3	Time	-	-	Tb Start
	W	3	Time	-	-	Tc Start
	W	3	Time	-	-	Td Start
	W	3	Time	-	-	Te Start
	W	3	Time	-	-	Tf Start

9.9.11 RTC tariff select setting

Instruction code	Operation	Size	Type	Unit	Range (Decimal)	Description
1073	W	1	UInt16	-	0-5	Ta Tariff select 0 = Tariff 1 1 = Tariff 2 ... 5= Tariff 6
	W	1	UInt16	-	0-5	Tb Tariff select
	W	1	UInt16	-	0-5	Tc Tariff select

Instruction code	Operation	Size	Type	Unit	Range (Decimal)	Description
	W	1	UInt16	-	0-5	Td Tariff select
	W	1	UInt16	-	0-5	Te Tariff select
	W	1	UInt16	-	0-5	Tf Tariff select

9.9.12 Device time setting

Instruction code	Operation	Size	Type	Unit	Range (Decimal)	Description
1200	W	1	UInt16	-	2000-2099	Year
	W	1	UInt16	-	1-12	Month
	W	1	UInt16	-	1-31	Date
	W	1	UInt16	-	0-23	Hour
	W	1	UInt16	-	0-59	Minute
	W	1	UInt16	-	0-59	Second

9.9.13 Communication parameter setting

Instruction code	Operation	Size	Type	Unit	Range (Decimal)	Description
1210	W	1	UInt16	-	1-247	Slave address
	W	1	UInt16	-	0-4	Baud rate 0 = 2400 1 = 4800 2 = 9600 3 = 19200 4 = 38400 5 = 57600 6 = 115200
	W	1	UInt16	-	0,1,2	Parity check 0 = NONE 1 = ODD 2 = EVEN
	W	1	UInt16	-	1,2	Stop bit 1 = 1bit 2 = 2bit

9.9.14 Reset setting

Instruction code	Operation	Size	Type	Unit	Range (Decimal)	Description
1301	W	1	UInt16	-	1-5	1:Reset Max.Min. 2:Reset Demand Max 3:Reset Tariff Energy 4:Reset Energy 5:Reset ALL

9.9.15 Relay output control mode

Instruction code	Operation	Size	Type	Unit	Range (Decimal)	Description
2000	W	1	UInt16	-	0-1	Control mode 0 = Manual 1 = Alarm

9.9.16 Relay output manual control

Instruction code	Operation	Size	Type	Unit	Range (Decimal)	Description
2001	W	1	UInt16	-	0-1	Relay output control 0 = open relay output 1 = closed relay output (Note: This setting is effective only when the relay output control mode is manual control mode)

9.9.17 Alarm setting

Instruction code	Operation	Size	Type	Unit	Range (Decimal)	Description
3000	W	1	UInt16	-	-	Alarm ID
	W	1	UInt16	-	0,1	Alarm Status 0=Disable 1=Enable
	-	1	UInt16	-	-	Reserve
	W	2	Float32	-	0-1000000	Alarm activation threshold

Instruction code	Operation	Size	Type	Unit	Range (Decimal)	Description
	W	2	Float32	%	-	Percentage error of alarm release point relative to alarm activation threshold Example: over current alarm activation threshold =100A alarm release point =5%. When the current value is less than $100-100*5\%=95A$, the alarm will be released
	W	1	UInt16	-	0,1	Buzzer 0=Unlinked 1=Linked
	W	1	UInt16	-	0,1	Relay 0=Unlinked 1=Linked

9. 10 Register list

The register list has the following headings:

Register alias	Register address	Operation read / write	Size	Type	Unit	Description
----------------	------------------	------------------------	------	------	------	-------------

- **Register alias:** Used to refer to the meaning of registers
- **Register address:** The start address of Modbus communication register is in decimal format, and the address is the real address without offset.
- **Operation:** Indicates the operation that the register can perform, R: readable; W: It can be written directly through 16 function code; WC: the current register needs to be configured indirectly by writing configuration data to the address starting from the instruction register 300.
- **Size:** Indicates how many MODBUS registers are occupied. One MODBUS register is 16bit.
- **Type:** For the type of data code, see the Data type table
- **Unit:** Unit of register value
- **Description:** Introduce the function of this register.

Data type table

Type	Description	Range
UInt16	Unsigned 16 bits integer	0~65535
Int16	Signed 16 bits integer	-32768~+32767
UInt32	Unsigned 32-bit integer	0~4294967295
UInt64	Unsigned 64 bits integer	0~18446744073709551615
Int64	Signed 64 bits integer	-9223372036854775808 ~ 9223372036854775808
UTF8	8-bit UTF code	Multibyte Unicode encoding
Float32	32-bit floating point	Standard IEEE floating point data (single precision)
Date Time	Time type	-

Date Time format

Byte	Position															
	15	14	13	12	11	10	9	8	7	6	5	4	3	2	1	0
1	Year(2000–2099)															
2	Month (1–12)								Date (1–31)							
3	Hour (0–23)								Minute (0–59)							
4	Millisecond (0–59999)															

9. 11 Modbus Register list

9.11.1 Equipment parameters

Register alias	Register start address (decimal)	Operation read / write	Size	Type	Unit	Description
Meter model	60	R	10	UTF8	-	
Serial Number	70	R	2	UInt32	-	
Firmware Version	72	R	1	UInt16	-	Format: X.Y.Z
Date and time	75	R/WC	4	Date time	-	Reg.75: Year 2000-2099 Reg.76: Month (b15:b8), Date (b7:b0) Reg. 77: Hour (b15:b8) ,Minute (b7:b0) Reg. 78: Millisecond

9.11.2 Communication parameter

Register alias	Register start address (decimal)	Operation read / write	Size	Type	Unit	Description
Slave address	80	R/WC	1	UInt16	-	1-247
Baud rate	81	R/WC	1	UInt16	-	0=2400 1=4800 2=9600 3=19200 4=38400 5=57600 6=115200
Parity	82	R/WC	1	UInt16	-	0 = None 1 = Odd 2 = Even
Stop bit	83	R/WC	1	UInt16	-	1 = 1 bit 2 = 2 bit

9.11.3 Relay

Register alias	Register start address (decimal)	Operation read / write	Size	Type	Unit	Description
Output control mode	200	R/WC	1	UInt16	-	Relay output control mode 0 = Manual control mode 1 = alarm output control mode
Relay output control	201	R/WC	1	UInt16	-	Relay output control 0 = Open 1 = Closed (Note: This setting is effective only when the relay output control mode is manual control mode)
Relay Output State	202	R	1	UInt16	-	Relay output status 0 = open 1 = closed

9.11.4 Digital input

Register alias	Register start address (decimal)	Operation read / write	Size	Type	Unit	Description
Digital input	210	R	1	UInt16	-	0 = DI1 open, DI2 open 1 = DI1 closed, DI2 open 2 = DI1 open, DI2 closed 3 = DI1 closed, DI2 closed

9.11.5 Voltage and current phase sequence

Register alias	Register start address (decimal)	Operation read / write	Size	Type	Unit	Description
Voltage current phase sequence state	220	R	1	UInt16	-	0 = voltage sequence is correct, current sequence is correct 1 = voltage sequence wrong, current sequence correct 2 = voltage sequence correct, current sequence wrong 3 = voltage sequence wrong, current sequence wrong

Note: Current phase sequence may be errors when the current is less than 1% of the nominal current

9.11.6 Configure instruction register

Register alias	Register start address (decimal)	Operation Read / write	Size	Type	Unit	Description
Instruction code	300	R/W	1	UInt16	-	
Instruction parameters001	301	R/W	1	UInt16	-	
Instruction parameters002	302	R/W	1	UInt16	-	
...	...	R/W	1	UInt16	-	
Instruction parameters123	423	R/W	1	UInt16	-	
Configuration instruction code	424	R	1	UInt16	-	
Configuration results	425	R	1	UInt16	-	0 = valid operation 80 = invalid instruction code 81 = invalid instruction parameter 82 = number of invalid instruction parameters 83= operation not executed

9.11.7 Power system

Register alias	Register start address (decimal)	Operation read / write	Size	Type	Unit	Description
Wiring mode	500	R/WC	1	UInt16	-	0=3P4W_4CT 1=3P4W_3CT 2=3P3W_3CT 3=3P3W_2CT 4=1P3W 5=1P2W
Grid frequency	501	R/WC	1	UInt16	Hz	
Nominal voltage	502	R/WC	1	UInt16	V	The VT ratio is not included
VT Ratio	503	R/WC	2	UInt32	-	Actual value = read value /10000
CT Ratio	505	R/WC	2	UInt32	-	Actual value = read value /10000

Register alias	Register start address (decimal)	Operation read / write	Size	Type	Unit	Description
Phase L1L2L3 current transformer						
Phase L1L2L3 Sensor Type	510	R/WC	1	UInt16	-	0 = Rogowski coil 1 = VCT
Phase L1L2L3 Rogowski Coil Pri	511	R/WC	2	UInt32	A	
Phase L1L2L3 Rogowski Coil Sec	513	R/WC	2	UInt32	mV@50 Hz mV@60 Hz	
Nominal current of Phase L1L2L3 Rogowski Coil	515	R/WC	2	UInt32	A	
Phase L1L2L3 VCT Pri	517	R/WC	2	UInt32	A	
Phase L1L2L3 VCT Sec	519	R/WC	2	UInt32	mV	
Nominal current of Phase L1L2L3 VCT	521	R/WC	2	UInt32	A	
N-phase current transformer						
Phase N Sensor Type	530	R/WC	1	UInt16	-	0 = Rogowski coil 1 = VCT
Phase N Rogowski Coil Pri	531	R/WC	2	UInt32	A	
Phase N Rogowski Coil Sec	533	R/WC	2	UInt32	mV@50 Hz mV@60 Hz	
Nominal current of Phase N Rogowski Coil	535	R/WC	2	UInt32	A	
Phase N VCT Pri	537	R/WC	2	UInt32	A	
Phase N VCT Sec	539	R/WC	2	UInt32	mV	
Nominal current of Phase N VCT	541	R/WC	2	UInt32	A	

9.11.8 Current Sensor Direction

Register alias	Register start address (decimal)	Operation read / write	Size	Type	Unit	Description
Phase A Current Sensor Direction	550	R/WC	1	UInt16	-	Phase A Current Sensor Direction 0=Positive (Default) 1=Negative
Phase B Current Sensor Direction	551	R/WC	1	UInt16	-	Phase B Current Sensor Direction 0=Positive (Default) 1=Negative
Phase C Current Sensor Direction	552	R/WC	1	UInt16	-	Phase C Current Sensor Direction 0=Positive (Default) 1=Negative

9.11.9 Current Sensor Channel

Register alias	Register start address (decimal)	Operation read / write	Size	Type	Unit	Description
Phase A Current Sensor Channel	553	R/WC	1	UInt16	-	Phase A Current Sensor Channel 0=channel 1 (Default) 1=channel 2 2=channel 3
Phase B Current Sensor Channel	554	R/WC	1	UInt16	-	Phase B Current Sensor Channel 0=channel 1 1=channel 2 (Default) 2=channel 3
Phase C Current Sensor Channel	555	R/WC	1	UInt16	-	Phase C Current Sensor Channel 0=channel 1 1=channel 2 2=channel 3 (Default)

9.11.10 Zero drift suppression parameter

Register alias	Register start address (decimal)	Operation read / write	Size	Type	Unit	Description
Voltage zero drift suppression	600	R/WC	1	UInt16	%	Voltage zero drift suppression Take (nominal voltage *VT ratio) as a reference Actual value = Read value /100
Current zero drift suppression	601	R/WC	1	UInt16	%	Current zero drift suppression Take (nominal current *CT ratio) as reference Actual value = Read value /100

9.11.11 Tariff parameter

Register alias	Register start address (decimal)	Operation read / write	Size	Type	Unit	Description
Current Tariff	800	R	1	UInt16	-	Current Tariff 0-5= Tariff 1- Tariff 6
Tariff switching mode	801	R/WC	1	UInt16	-	Tariff switching mode 0=Manual 1=RTC
Manual Tariff selection	802	R/WC	1	UInt16	-	Manual Tariff selection 0-5= Tariff 1- Tariff 6
RTC Ta Start	803	R/WC	3	Time	-	RTC Ta Start
RTC Tb Start	806	R/WC	3	Time	-	RTC Tb Start
RTC Tc Start	809	R/WC	3	Time	-	RTC Tc Start
RTC Td Start	812	R/WC	3	Time	-	RTC Td Start
RTC Te Start	815	R/WC	3	Time	-	RTC Te Start
RTC Tf Start	818	R/WC	3	Time	-	RTC Tf Start
RTC Ta tariff select	821	R/WC	1	UInt16	-	Ta tariff select 0-5= Tariff 1- Tariff 6
RTC Tb tariff select	822	R/WC	1	UInt16	-	Tb tariff select 0-5= Tariff 1- Tariff 6
RTC Tc tariff select	823	R/WC	1	UInt16	-	Tc tariff select 0-5= Tariff 1- Tariff 6
RTC Td tariff select	824	R/WC	1	UInt16	-	Td tariff select 0-5= Tariff 1- Tariff 6
RTC Te tariff select	825	R/WC	1	UInt16	-	Te tariff select 0-5= Tariff 1- Tariff 6
RTC Tf tariff select	826	R/WC	1	UInt16	-	Tf tariff select 0-5= Tariff 1- Tariff 6

9.11.12 Voltage, current, power, power factor

Register alias	Register start address (decimal)	Operation read / write	Size	Type	Unit	Description
Current						
I1	1000	R	2	Float32	A	Phase L1 current
I2	1002	R	2	Float32	A	Phase L2 current
I3	1004	R	2	Float32	A	Phase L3 current
Current Avg	1006	R	2	Float32	A	Average value of L1L2L3 three-phase current
IN	1008	R	2	Float32	A	Phase N current
Phase voltage						
U1	1010	R	2	Float32	V	U1-UN voltage
U2	1012	R	2	Float32	V	U2-UN voltage
U3	1014	R	2	Float32	V	U3-UN voltage
Phase Voltage Avg	1016	R	2	Float32	V	Average value of L1L2L3 three-phase phase voltage
Line voltage						
U12	1020	R	2	Float32	V	U1-U2 voltage
U23	1022	R	2	Float32	V	U2-U3 voltage
U31	1024	R	2	Float32	V	U3-U1 voltage
Line Voltage Avg	1026	R	2	Float32	V	Average value of three-phase line voltage
Active power						
P1	1028	R	2	Float32	kW	Phase L1 Active power
P2	1030	R	2	Float32	kW	Phase L2 Active power
P3	1032	R	2	Float32	kW	Phase L3 Active power
PTotal	1034	R	2	Float32	kW	Total Active power
Reactive power						
Q1	1036	R	2	Float32	kVAR	Phase L1 Reactive power
Q2	1038	R	2	Float32	kVAR	Phase L2 Reactive power
Q3	1040	R	2	Float32	kVAR	Phase L3 Reactive power
QTotal	1042	R	2	Float32	kVAR	Total Reactive power
Apparent power						
S1	1044	R	2	Float32	kVA	Phase L1 Apparent power
S2	1046	R	2	Float32	kVA	Phase L2 Apparent power
S3	1048	R	2	Float32	kVA	Phase L3 Apparent power
STotal	1050	R	2	Float32	kVA	Total Apparent power
Power factor						
PF1	1052	R	2	Float32	-	Phase L1 Power factor

Register alias	Register start address (decimal)	Operation read / write	Size	Type	Unit	Description
PF2	1054	R	2	Float32	-	Phase L2 Power factor
PF3	1056	R	2	Float32	-	Phase L3 Power factor
PFTotal	1058	R	2	Float32	-	Total Power factor
Displacement Power factor						
DPF1	1060	R	2	Float32	-	Phase L1 DPF
DPF2	1062	R	2	Float32	-	Phase L2 DPF
DPF3	1064	R	2	Float32	-	Phase L3 DPF
DPFTotal	1066	R	2	Float32	-	Total DPF
Frequency						
Freq1	1068	R	2	Float32	Hz	Phase L1 frequency
Freq2	1070	R	2	Float32	Hz	Phase L2 frequency
Freq3	1072	R	2	Float32	Hz	Phase L3 frequency
FreqTotal	1074	R	2	Float32	Hz	Total frequency

9.11.13 Energy

There are two types of energy, positive energy and reverse energy.

When the total electric energy reaches 1.0×10^9 kWh, 1.0×10^9 kvarh, or 1.0×10^9 KVAh, the electric energy of each phase will be cleared automatically.

Register alias	Register start address (decimal)	Operation read / write	Size	Type	Unit	Description
Active Energy-Int64						
EP1Imp	2500	R	4	Int64	Wh	Phase L1 Positive active energy
EP2Imp	2504	R	4	Int64	Wh	Phase L2 Positive active energy
EP3Imp	2508	R	4	Int64	Wh	Phase L3 Positive active energy
EPImp	2512	R	4	Int64	Wh	Total Positive active energy
EP1Exp	2516	R	4	Int64	Wh	Phase L1 Reverse active energy
EP2Exp	2520	R	4	Int64	Wh	Phase L2 Reverse active energy
EP3Exp	2524	R	4	Int64	Wh	Phase L3 Reverse active energy
EPExp	2528	R	4	Int64	Wh	Total Reverse active energy
Reactive energy-Int64						
EQ1Imp	2532	R	4	Int64	VARh	Phase L1 Positive reactive energy
EQ2Imp	2536	R	4	Int64	VARh	Phase L2 Positive reactive energy

Register alias	Register start address (decimal)	Operation read / write	Size	Type	Unit	Description
EQ3Imp	2540	R	4	Int64	VARh	Phase L3 Positive reactive energy
EQImp	2544	R	4	Int64	VARh	Total Positive reactive energy
EQ1Exp	2548	R	4	Int64	VARh	Phase L1 Reverse reactive energy
EQ2Exp	2552	R	4	Int64	VARh	Phase L2 Reverse reactive energy
EQ3Exp	2556	R	4	Int64	VARh	Phase L3 Reverse reactive energy
EQExp	2560	R	4	Int64	VARh	Total Reverse reactive energy
Apparent Energy-Int64						
ES1	2564	R	4	Int64	VAh	Phase L1 Apparent Energy
ES2	2568	R	4	Int64	VAh	Phase L2 Apparent Energy
ES3	2572	R	4	Int64	VAh	Phase L3 Apparent Energy
ES	2576	R	4	Int64	VAh	Total Apparent Energy
UInt32 Energy						
Active Energy- UInt32						
EP1Imp	2600	R	2	UInt32	kWh	Phase L1 Positive active energy
EP2Imp	2602	R	2	UInt32	kWh	Phase L2 Positive active energy
EP3Imp	2604	R	2	UInt32	kWh	Phase L3 Positive active energy
EPImp	2606	R	2	UInt32	kWh	Total Positive active energy
EP1Exp	2608	R	2	UInt32	kWh	Phase L1 Reverse active energy
EP2Exp	2610	R	2	UInt32	kWh	Phase L2 Reverse active energy
EP3Exp	2612	R	2	UInt32	kWh	Phase L3 Reverse active energy
EPExp	2614	R	2	UInt32	kWh	Total Reverse active energy
Reactive energy- UInt32						
EQ1Imp	2616	R	2	UInt32	kVARh	Phase L1 Positive reactive energy
EQ2Imp	2618	R	2	UInt32	kVARh	Phase L2 Positive reactive energy
EQ3Imp	2620	R	2	UInt32	kVARh	Phase L3 Positive reactive energy
EQImp	2622	R	2	UInt32	kVARh	Total Positive reactive energy
EQ1Exp	2624	R	2	UInt32	kVARh	Phase L1 Reverse reactive energy
EQ2Exp	2626	R	2	UInt32	kVARh	Phase L2 Reverse reactive energy
EQ3Exp	2628	R	2	UInt32	kVARh	Phase L3 Reverse reactive energy
EQExp	2630	R	2	UInt32	kVARh	Total Reverse reactive energy
Apparent Energy-UInt32						

Register alias	Register start address (decimal)	Operation read / write	Size	Type	Unit	Description
ES1	2632	R	2	UInt32	kVAh	Phase L1 Apparent Energy
ES2	2634	R	2	UInt32	kVAh	Phase L2 Apparent Energy
ES3	2636	R	2	UInt32	kVAh	Phase L3 Apparent Energy
ES	2638	R	2	UInt32	kVAh	Total Apparent Energy

9.11.14 Tariff Energy

Tariff Energy types are Int64 and UInt32, whose unit size is different.

When the rate of electricity reaches 1.0×10^9 kWh, 1.0×10^9 kVarh, or 1.0×10^9 kVAh, each Tariff Energy will be automatically cleared to zero.

Register alias	Register start address (decimal)	Operation read / write	Size	Type	Unit	Description
Tariff Energy-Int64						
ET1	2700	R	4	Int64	Wh	Tariff 1 Active Energy
ET2	2704	R	4	Int64	Wh	Tariff 2 Active Energy
ET3	2708	R	4	Int64	Wh	Tariff 3 Active Energy
ET4	2712	R	4	Int64	Wh	Tariff 4 Active Energy
ET5	2716	R	4	Int64	Wh	Tariff 5 Active Energy
ET6	2720	R	4	Int64	Wh	Tariff 6 Active Energy
Tariff Energy-UInt32						
ET1	2750	R	2	UInt32	kWh	Tariff 1 Active Energy
ET2	2752	R	2	UInt32	kWh	Tariff 2 Active Energy
ET3	2754	R	2	UInt32	kWh	Tariff 3 Active Energy
ET4	2756	R	2	UInt32	kWh	Tariff 4 Active Energy
ET5	2758	R	2	UInt32	kWh	Tariff 5 Active Energy
ET6	2760	R	2	UInt32	kWh	Tariff 6 Active Energy

9.11.15 Demand register

Register alias	Register start address (decimal)	Operation read / write	Size	Type	Unit	Description
Basic parameters of demand						

Register alias	Register start address (decimal)	Operation read / write	Size	Type	Unit	Description
DMDMethod	3000	R/WC	1	UInt16	-	Demand calculation method: 0= sliding type 1= fixed
DMD block	3001	R/RC	1	UInt16	Minute	Demand interval
PDMD Reset Time	3002	R	4	Date time	-	Peak demand reset date and time
Power demand						
P1Demand	3020	R	2	Float32	kW	Current active power demand of phase L1
P1PeakDemand	3022	R	2	Float32	kW	Peak demand of phase L1 active power
P1PeakDemand Date	3024	R	4	Date time	-	Occurrence time of peak demand of phase L1 active power
P2Demand	3028	R	2	Float32	kW	Current active power demand of phase 2
P2PeakDemand	3030	R	2	Float32	kW	Peak demand of phase 2 active power
P2PeakDemand Date	3032	R	4	Date time	-	Occurrence time of peak demand of phase 2 active power
P3Demand	3036	R	2	Float32	kW	Current active power demand of phase 3
P3PeakDemand	3038	R	2	Float32	kW	Peak demand of phase 3 active power
P3PeakDemand Date	3040	R	4	Date time	-	Occurrence time of peak demand of phase 3 active power
PSUMDemand	3044	R	2	Float32	kW	Current total active power demand
PSUMPeakDemand	3046	R	2	Float32	kW	Peak demand of total active power
PSUMPeakDemandDate	3048	R	4	Date time	-	Occurrence time of peak demand of total active power
Q1Demand	3052	R	2	Float32	kVar	Current reactive power demand of phase L1
Q1PeakDemand	3054	R	2	Float32	kVar	Peak demand of phase L1 reactive power
Q1PeakDemand Date	3056	R	4	Date time	-	Occurrence time of peak demand of phase L1 reactive power
Q2Demand	3060	R	2	Float32	kVar	Current reactive power demand of phase L2
Q2PeakDemand	3062	R	2	Float32	kVar	Peak demand of phase L2 reactive power

Register alias	Register start address (decimal)	Operation read / write	Size	Type	Unit	Description
Q2PeakDemandDate	3064	R	4	Date time	-	Occurrence time of peak demand of phase L2 reactive power
Q3Demand	3068	R	2	Float32	kVar	Current reactive power demand of phase L3
Q3PeakDemand	3070	R	2	Float32	kVar	Peak demand of phase L3 reactive power
Q3PeakDemandDate	3072	R	4	Date time	-	Occurrence time of peak demand of phase L3 reactive power
QSUMDemand	3076	R	2	Float32	kVar	Current total reactive power demand
QSUMPeakDemand	3078	R	2	Float32	kVar	Peak demand of total reactive power
QSUMPeakDemandDate	3080	R	4	Date time	-	Occurrence time of peak demand of total reactive power
S1Demand	3084	R	2	Float32	kVa	Current apparent power demand of phase L1
S1PeakDemand	3086	R	2	Float32	kVa	Peak demand of phase L1 apparent power
S1PeakDemandDate	3088	R	4	Date time	-	Occurrence time of peak demand of phase L1 apparent power
S2Demand	3092	R	2	Float32	kVa	Current apparent power demand of phase L2
S2PeakDemand	3094	R	2	Float32	kVa	Peak demand of phase L2 apparent power
S2PeakDemandDate	3096	R	4	Date time	-	Occurrence time of peak demand of phase L2 apparent power
S3Demand	3100	R	2	Float32	kVa	Current apparent power demand of phase L3
S3PeakDemand	3102	R	2	Float32	kVa	Peak demand of phase L3 apparent power
S3PeakDemandDate	3104	R	4	Date time	-	Occurrence time of peak demand of phase L3 apparent power
SSUMDemand	3108	R	2	Float32	kVa	Current total apparent power demand
SSUMPeakDemand	3110	R	2	Float32	kVa	Peak demand of total apparent power
SSUMPeakDemandDate	3112	R	4	Date time	-	Occurrence time of peak demand of total apparent power

9.11.16 Voltage and current harmonic register

Register name	Register start address (decimal)	Operation	Size	Type	Unit	Description
Current harmonic percentage						
I1THD	4000	R	2	Float32	%	Phase L1 current total harmonic percentage
I2THD	4002	R	2	Float32	%	Phase L2 current total harmonic percentage
I3THD	4004	R	2	Float32	%	Phase L3 current total harmonic percentage
I1TOHD	4006	R	2	Float32	%	Phase L1 current odd total harmonic percentage
I2TOHD	4008	R	2	Float32	%	Phase L2 current odd total harmonic percentage
I3TOHD	4010	R	2	Float32	%	Phase L3 current odd total harmonic percentage
I1TEHD	4012	R	2	Float32	%	Phase L1 current even total harmonic percentage
I2TEHD	4014	R	2	Float32	%	Phase L2 current even total harmonic percentage
I3TEHD	4016	R	2	Float32	%	Phase L3 current even total harmonic percentage
I1HD1	4018	R	2	Float32	%	1st harmonic percentage of phase L1 current
I2HD1	4020	R	2	Float32	%	1st harmonic percentage of phase L2 current
I3HD1	4022	R	2	Float32	%	1st harmonic percentage of phase L3 current
...	4024-4311	The 2nd-49th harmonic percentage of L1L2L3 phase current
I1HD50	4312	R	2	Float32	%	The 50th harmonic percentage of phase L1 current
I2HD50	4314	R	2	Float32	%	The 50th harmonic percentage of phase L2 current
I3HD50	4316	R	2	Float32	%	The 50th harmonic percentage of phase L3 current
Current harmonic value						
I1HDV1	4400	R	2	Float32	A	Fundamental current value of phase L1 current
I2HDV1	4402	R	2	Float32	A	Fundamental current value of phase L2 current
I3HDV1	4404	R	2	Float32	A	Fundamental current value of phase L3 current
...	4406-4693	The 2nd-49th harmonic current value of L1L2L3 phase current
I1HDV50	4694	R	2	Float32	A	The 50th harmonic current value of phase L1 current

Register name	Register start address (decimal)	Operation	Size	Type	Unit	Description
I2HDV50	4696	R	2	Float32	A	The 50th harmonic current value of phase L2 current
I3HDV50	4698	R	2	Float32	A	The 50th harmonic current value of phase L3 current
Voltage harmonic percentage						
U1THD	5000	R	2	Float32	%	Phase L1 voltage total harmonic percentage
U2THD	5002	R	2	Float32	%	Phase L2 voltage total harmonic percentage
U3THD	5004	R	2	Float32	%	Phase L3 voltage total harmonic percentage
U1TOHD	5006	R	2	Float32	%	Phase L1 voltage odd total harmonic percentage
U2TOHD	5008	R	2	Float32	%	Phase L2 voltage odd total harmonic percentage
U3TOHD	5010	R	2	Float32	%	Phase L3 voltage odd total harmonic percentage
U1TEHD	5012	R	2	Float32	%	Phase L1 voltage even total harmonic percentage
U2TEHD	5014	R	2	Float32	%	Phase L2 voltage even total harmonic percentage
U3TEHD	5016	R	2	Float32	%	Phase L3 voltage even total harmonic percentage
U1HD1	5018	R	2	Float32	%	The 1st harmonic percentage of phase L1 voltage
U2HD1	5020	R	2	Float32	%	The 1st harmonic percentage of phase L2 voltage
U3HD1	5022	R	2	Float32	%	The 1st harmonic percentage of phase L3 voltage
...	5024-5311	The 2nd-49th harmonic percentage of L1L2L3 phase voltage
U1HD50	5312	R	2	Float32	%	The 50th harmonic percentage of phase L1 voltage
U2HD50	5314	R	2	Float32	%	The 50th harmonic percentage of phase L2 voltage
U3HD50	5316	R	2	Float32	%	The 50th harmonic percentage of phase L3 voltage
Voltage harmonic value						
U1HDV1	5400	R	2	Float32	V	The 1st harmonic voltage value of phase L1 voltage
U2HDV1	5402	R	2	Float32	V	The 1st harmonic voltage value of phase L2 voltage
U3HDV1	5404	R	2	Float32	V	The 1st harmonic voltage value of phase L3 voltage
...	5406-5693	The 2nd-49th harmonic voltage value of L1L2L3 phase voltage

Register name	Register start address (decimal)	Operation	Size	Type	Unit	Description
U1HDV50	5694	R	2	Float32	V	The 50th harmonic voltage value of phase L1 voltage
U2HDV50	5696	R	2	Float32	V	The 50th harmonic voltage value of phase L2 voltage
U3HDV50	5698	R	2	Float32	V	The 50th harmonic voltage value of phase L3 voltage

9.11.17 Max.&Min.

Register name	Register start address (decimal)	Operation	Size	Type	Unit	Description
Current max / min						
I1Max	6000	R	2	Float32	A	Phase L1 Maximum current
I2Max	6002	R	2	Float32	A	Phase L2 Maximum current
I3Max	6004	R	2	Float32	A	Phase L3 Maximum current
I1VGMax	6006	R	2	Float32	A	Maximum three phase average current
IN Max	6008	R	2	Float32	A	Phase N Maximum current
I1Min	6010	R	2	Float32	A	Phase L1 Minimum current
I2Min	6012	R	2	Float32	A	Phase L2 Minimum current
I3Min	6014	R	2	Float32	A	Phase L3 Minimum current
I1VGMin	6016	R	2	Float32	A	Minimum three phase average current
IN Min	6018	R	2	Float32	A	Phase N Minimum current
Voltage max / min						
U1Max	6020	R	2	Float32	V	U1-UN Maximum phase voltage
U2Max	6022	R	2	Float32	V	U2-UN Maximum phase voltage
U3Max	6024	R	2	Float32	V	U3-UN Maximum phase voltage
Phase UAVGMax	6026	R	2	Float32	V	Maximum value of average value of three-phase phase voltage.
U1Min	6030	R	2	Float32	V	U1-UN Minimum phase voltage
U2Min	6032	R	2	Float32	V	U2-UN Minimum phase voltage
U3Min	6034	R	2	Float32	V	U3-UN Minimum phase voltage
U1VGMin	6036	R	2	Float32	V	Minimum value of average value of three-phase phase voltage.
U12Max	6040	R	2	Float32	V	U1-U2 Maximum wire voltage
U23Max	6042	R	2	Float32	V	U2-U3 Maximum wire voltage
U31Max	6044	R	2	Float32	V	U3-U1 Maximum wire voltage

LineUAVGMax	6046	R	2	Float32	V	Maximum value of average value of three-phase phase voltage.
U12Min	6050	R	2	Float32	V	U1-U2 Minimum phase voltage
U23Min	6052	R	2	Float32	V	U2SS-U3 Minimum phase voltage
U31Min	6054	R	2	Float32	V	U3-U1 Minimum phase voltage
LineUAVGMin	6056	R	2	Float32	V	Minimum value of average value of three-phase phase voltage.
Maximum / minimum power						
P1Max	6060	R	2	Float32	kW	Maximum active power of phase L1
P2Max	6062	R	2	Float32	kW	Maximum active power of phase L2
P3Max	6064	R	2	Float32	kW	Maximum active power of phase L3
PSUMMax	6066	R	2	Float32	kW	Maximum value of three-phase total active power
P1Min	6070	R	2	Float32	kW	Minimum active power of phase L1
P2Min	6072	R	2	Float32	kW	Minimum active power of phase L2
P3Min	6074	R	2	Float32	kW	Minimum active power of phase L3
PSUMMin	6076	R	2	Float32	kW	Minimum value of three-phase total active power
Reactive Power Max / min						
Q1Max	6080	R	2	Float32	kVar	Maximum value of phase L1 reactive power
Q2Max	6082	R	2	Float32	kVar	Maximum value of phase L2 reactive power
Q3Max	6084	R	2	Float32	kVar	Maximum value of phase L3 reactive power
QSUMMax	6086	R	2	Float32	kVar	Maximum value of three-phase total reactive power
Q1Min	6090	R	2	Float32	kVar	Minimum value of phase L1 reactive power
Q2Min	6092	R	2	Float32	kVar	Minimum value of phase L2 reactive power
Q3Min	6094	R	2	Float32	kVar	Minimum value of phase L3 reactive power
QSUMMin	6096	R	2	Float32	kVar	Minimum value of three-phase total reactive power
Apparent power max / min						
S1Max	6100	R	2	Float32	kVa	Maximum apparent power of phase L1
S2Max	6102	R	2	Float32	kVa	Maximum apparent power of phase L2
S3Max	6104	R	2	Float32	kVa	Maximum apparent power of

						phase L3
SSUMMax	6106	R	2	Float32	kVa	Maximum three-phase total apparent power
S1Min	6110	R	2	Float32	kVa	Minimum apparent power of phase L1
S2Min	6112	R	2	Float32	kVa	Minimum apparent power of phase L2
S3Min	6114	R	2	Float32	kVa	Minimum apparent power of phase L3
SSUMMin	6116	R	2	Float32	kVa	Minimum three phase total apparent power

9.11.18 Unbalance degree

Register name	Register start address (decimal)	Operation	Size	Type	Unit	Description
Voltage negative sequence unbalance degree	7000	R	2	Float32	%	Voltage negative sequence unbalance degree
Voltage zero sequence unbalance degree	7002	R	2	Float32	%	Voltage zero sequence unbalance degree
Current negative sequence unbalance degree	7004	R	2	Float32	%	Current negative sequence unbalance degree
Current zero sequence unbalance degree	7006	R	2	Float32	%	Current zero sequence unbalance degree

9.11.19 Current K-factor and crest factor register

Register name	Register start address (decimal)	Operation	Size	Type	Unit	Description
Current K factor						
KF1	8000	R	2	Float32	-	Current K factor of phase L1
KF2	8002	R	2	Float32	-	Current K factor of phase L2
KF3	8004	R	2	Float32	-	Current K factor of phase L3

9.11.20 Voltage and current angle register

Register name	Register start address (decimal)	Operation	Size	Type	Unit	Description
Voltage Angle						
U1	8100	R	2	Float32	°	Angle phase L1 voltage
U2	8102	R	2	Float32	°	Angle phase L2 voltage
U3	8104	R	2	Float32	°	Angle phase L3 voltage
Current Angle						
I1	8106	R	2	Float32	°	Angle phase L1 current
I2	8108	R	2	Float32	°	Angle phase L2 current
I3	8110	R	2	Float32	°	Angle phase L3 current
Angle between voltage and current						
UI1	8112	R	2	Float32	°	Angle between voltage and current of phase L1
UI2	8114	R	2	Float32	°	Angle between voltage and current of phase L2
UI3	8116	R	2	Float32	°	Angle between voltage and current of phase L3

9.11.21 Alarm

Register name	Register start address (decimal)	Operation	Size	Type	Unit	Description
Alarm map						
Enabled alarm bitmap						
Enabled alarm bitmap1	10000	R	1	bitmap	-	0=Alarm disabled 1=Alarm enabled Bit N(0-15)=Alarm ID N(1-16)
Enabled alarm bitmap2	10001	R	1	bitmap	-	0=Alarm disabled 1=Alarm enabled Bit N(0-15)=Alarm ID N(17-32)
Actiactive alarm bit map						
Actiactive alarm bit map 1	10010	R	1	bitmap	-	0=Alarm not activated 1=Alarm activation Bit N(0-15)=Alarm ID N(1-16)
Actiactive alarm bit map 2	10011	R	1	bitmap	-	0=Alarm not activated 1=Alarm activation Bit N(0-15)=Alarm ID N(17-32)

Register name	Register start address (decimal)	Operation	Size	Type	Unit	Description
Current alarm output bitmap						
(Note: Up to 1 alarm output at the same time)						
Current alarm output bitmap 1	10020	R	1	bitmap	-	0=Alarm not output 1=Alarm output Bit N(0-15)=Alarm ID N(1-16)
Current alarm output bitmap 2	10021	R	1	bitmap	-	0=Alarm not output 1=Alarm output Bit N(0-15)=Alarm ID N(17-32)
Alarm parameters						
Current Over , each phase (Note: One phase above the activation threshold produces an alarm, all phases below the alarm release point, alarm release)						Alarm ID=1
Alarm Status	10100	R/WC	1	UInt16	-	Alarm Status 0=Disable 1=Enable
Alarm activation threshold	10102	R/WC	2	Float32	A	Alarm activation threshold
Alarm release point	10104	R/WC	2	Float32	%	Percentage error of alarm release point relative to alarm activation threshold Example: over current alarm activation threshold =100A alarm release point =5%. When the current value is less than $100-100*5\%=95A$, the alarm will be released
Buzzer	10106	R/WC	1	UInt16	-	Buzzer 0=Unlinked 1=Linked
Relay	10107	R/WC	1	UInt16	-	Relay 0=Unlinked 1=Linked (Note: Control is valid only valid if the relay output mode is alarm output mode)
Current Under, each phase						Alarm ID=2
Alarm Status	10120	R/WC	1	UInt16	-	Alarm Status 0=Disable 1=Enable

Register name	Register start address (decimal)	Operation	Size	Type	Unit	Description
Alarm activation threshold	10122	R/WC	2	Float32	A	Alarm activation threshold
Alarm release point	10124	R/WC	2	Float32	%	Percentage error of alarm release point relative to alarm activation threshold
Buzzer	10126	R/WC	1	UInt16	-	Buzzer 0=Unlinked 1=Linked
Relay	10127	R/WC	1	UInt16	-	Relay 0=Unlinked 1=Linked
Phase Voltage Over, L-N						Alarm ID=3
Alarm Status	10140	R/WC	1	UInt16	-	Alarm Status 0=Disable 1=Enable
Alarm activation threshold	10142	R/WC	2	Float32	V	Alarm activation threshold
Alarm release point	10144	R/WC	2	Float32	%	Percentage error of alarm release point relative to alarm activation threshold
Buzzer	10146	R/WC	1	UInt16	-	Buzzer 0=Unlinked 1=Linked
Relay	10147	R/WC	1	UInt16	-	Relay 0=Unlinked 1=Linked
Phase Voltage Under, L-N						Alarm ID=4
Alarm Status	10160	R/WC	1	UInt16	-	Alarm Status 0=Disable 1=Enable
Alarm activation threshold	10162	R/WC	2	Float32	V	Alarm activation threshold
Alarm release point	10164	R/WC	2	Float32	%	Percentage error of alarm release point relative to alarm activation threshold
Buzzer	10166	R/WC	1	UInt16	-	Buzzer 0=Unlinked 1=Linked
Relay	10167	R/WC	1	UInt16	-	Relay 0=Unlinked 1=Linked
Line Voltage Over, L-L						Alarm ID=5

Register name	Register start address (decimal)	Operation	Size	Type	Unit	Description
Alarm Status	10180	R/WC	1	UInt16	-	Alarm Status 0=Disable 1=Enable
Alarm activation threshold	10182	R/WC	2	Float32	V	Alarm activation threshold
Alarm release point	10184	R/WC	2	Float32	%	Percentage error of alarm release point relative to alarm activation threshold
Buzzer	10186	R/WC	1	UInt16	-	Buzzer 0=Unlinked 1=Linked
Relay	10187	R/WC	1	UInt16	-	Relay 0=Unlinked 1=Linked
Line Voltage Under, L-L					Alarm ID=6	
Alarm Status	10200	R/WC	1	UInt16	-	Alarm Status 0=Disable 1=Enable
Alarm activation threshold	10202	R/WC	2	Float32	V	Alarm activation threshold
Alarm release point	10204	R/WC	2	Float32	%	Percentage error of alarm release point relative to alarm activation threshold
Buzzer	10206	R/WC	1	UInt16	-	Buzzer 0=Unlinked 1=Linked
Relay	10207	R/WC	1	UInt16	-	Relay 0=Unlinked 1=Linked
Power P Over, (absolute value)					Alarm ID=10	
Alarm Status	10220	R/WC	1	UInt16	-	Alarm Status 0=Disable 1=Enable
Alarm activation threshold	10222	R/WC	2	Float32	kW	Alarm activation threshold
Alarm release point	10224	R/WC	2	Float32	%	Percentage error of alarm release point relative to alarm activation threshold
Buzzer	10226	R/WC	1	UInt16	-	Buzzer 0=Unlinked 1=Linked

Register name	Register start address (decimal)	Operation	Size	Type	Unit	Description
Relay	10227	R/WC	1	UInt16	-	Relay 0=Unlinked 1=Linked
Power Q Over, (absolute value)						Alarm ID=14
Alarm Status	10240	R/WC	1	UInt16	-	Alarm Status 0=Disable 1=Enable
Alarm activation threshold	10242	R/WC	2	Float32	kVar	Alarm activation threshold
Alarm release point	10244	R/WC	2	Float32	%	Percentage error of alarm release point relative to alarm activation threshold
Buzzer	10246	R/WC	1	UInt16	-	Buzzer 0=Unlinked 1=Linked
Relay	10247	R/WC	1	UInt16	-	Relay 0=Unlinked 1=Linked
Power S Over						Alarm ID=18
Alarm Status	10260	R/WC	1	UInt16	-	Alarm Status 0=Disable 1=Enable
Alarm activation threshold	10262	R/WC	2	Float32	kVA	Alarm activation threshold
Alarm release point	10264	R/WC	2	Float32	%	Percentage error of alarm release point relative to alarm activation threshold
Buzzer	10266	R/WC	1	UInt16	-	Buzzer 0=Unlinked 1=Linked
Relay	10267	R/WC	1	UInt16	-	Relay 0=Unlinked 1=Linked
Power P DMD Over, (current)						Alarm ID=20
Alarm Status	10280	R/WC	1	UInt16	-	Alarm Status 0=Disable 1=Enable
Alarm activation threshold	10282	R/WC	2	Float32	kW	Alarm activation threshold
Alarm release point	10284	R/WC	2	Float32	%	Percentage error of alarm release point relative to alarm activation threshold

Register name	Register start address (decimal)	Operation	Size	Type	Unit	Description
Buzzer	10286	R/WC	1	UInt16	-	Buzzer 0=Unlinked 1=Linked
Relay	10287	R/WC	1	UInt16	-	Relay 0=Unlinked 1=Linked
Power Q DMD Over, (absolute value) (current)						Alarm ID=21
Alarm Status	10300	R/WC	1	UInt16	-	Alarm Status 0=Disable 1=Enable
Alarm activation threshold	10302	R/WC	2	Float32	kVar	Alarm activation threshold
Alarm release point	10304	R/WC	2	Float32	%	Percentage error of alarm release point relative to alarm activation threshold
Buzzer	10306	R/WC	1	UInt16	-	Buzzer 0=Unlinked 1=Linked
Relay	10307	R/WC	1	UInt16	-	Relay 0=Unlinked 1=Linked
Power S DMD Over, (current)						Alarm ID=22
Alarm Status	10320	R/WC	1	UInt16	-	Alarm Status 0=Disable 1=Enable
Alarm activation threshold	10322	R/WC	2	Float32	kVA	Alarm activation threshold
Alarm release point	10324	R/WC	2	Float32	%	Percentage error of alarm release point relative to alarm activation threshold
Buzzer	10326	R/WC	1	UInt16	-	Buzzer 0=Unlinked 1=Linked
Relay	10327	R/WC	1	UInt16	-	Relay 0=Unlinked 1=Linked
THD-U Over,each phase						Alarm ID=30
Alarm Status	10340	R/WC	1	UInt16	-	Alarm Status 0=Disable 1=Enable
Alarm activation threshold	10342	R/WC	2	Float32	%	Alarm activation threshold

Register name	Register start address (decimal)	Operation	Size	Type	Unit	Description
Alarm release point	10344	R/WC	2	Float32	%	Percentage error of alarm release point relative to alarm activation threshold
Buzzer	10346	R/WC	1	UInt16	-	Buzzer 0=Unlinked 1=Linked
Relay	10347	R/WC	1	UInt16	-	Relay 0=Unlinked 1=Linked
THD-I Over,each phase						Alarm ID=31
Alarm Status	10360	R/WC	1	UInt16	-	Alarm Status 0=Disable 1=Enable
Alarm activation threshold	10362	R/WC	2	Float32	%	Alarm activation threshold
Alarm release point	10364	R/WC	2	Float32	%	Percentage error of alarm release point relative to alarm activation threshold
Buzzer	10366	R/WC	1	UInt16	-	Buzzer 0=Unlinked 1=Linked
Relay	10367	R/WC	1	UInt16	-	Relay 0=Unlinked 1=Linked

10. Revision History

Version	Date	Change	By
V1.0	2023/05/25	Create document	Walter
V1.1	2023/06/26	Fixed the stop bit value of communication parameters was defined incorrectly	Walter

ROGOWSKI TECHNOLOGY (SHANGHAI) CO., LTD.

Phone: +86 21 64850006

Mobile (WeChat) number: 18621563567

Email: info@meatrol.cn

Website: www.rogowski.cn www.meatrol.cn

