

# MC-60

## Multi-Circuit smart meter

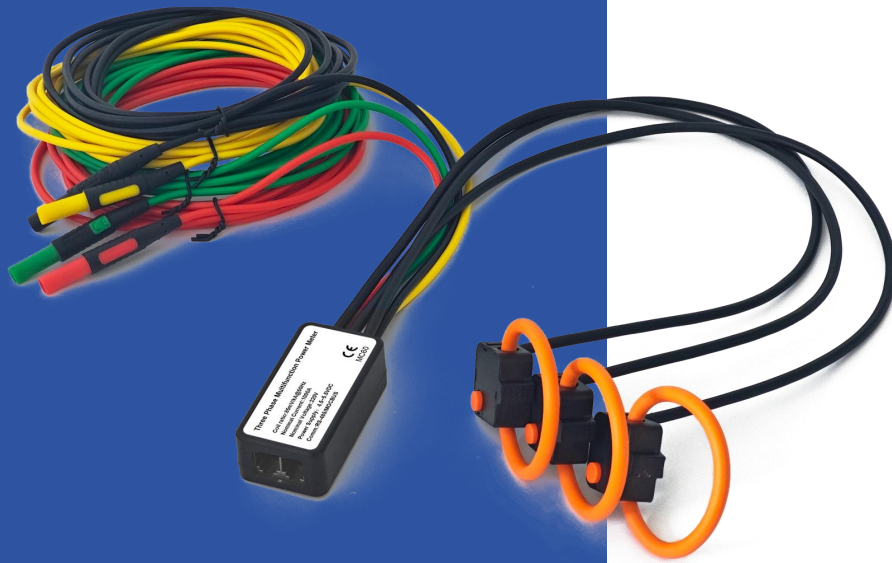

**MEATROL**<sup>®</sup>  
ELECTRICAL



## INTRO

The MC60 is a Multi-Circuit smart meter that offers customizable features such as Rogowski coils and open-end voltage type CTs, allowing for non-invasive testing. This design simplifies testing procedures and saves on construction costs. Its integrated structure greatly reduces the likelihood of errors during wiring and also contributes to a smaller meter size. The meter can be interconnected with others through an RJ12 interface, making it ideal for monitoring multiple circuits simultaneously.

## PECULIARITY

### Multi-Circuit Monitoring:

Supports up to 247 circuits interconnected simultaneously.

### Integrated Design:

Fixed power supply and current transformer.

### Compact Size:

37mm\*75mm

# Key characteristics

## Medium distance multi-point measurement Solutions:

- Scattered Installation with Centralized Reading
- Analyzes and records overall energy usage.
- 0.5s level measurement accuracy.
- Customizable current sensor measurement range, with no theoretical maximum limit.
- Capable of measuring active power (P) and reactive power (Q), as well as power factor.

## Multi-cannel Electric Power Quality Analysis Solution:

- Capable of measuring multiple electrical parameters on phases A, B, and C, including current, voltage, power factor, harmonics, power, and energy. Provides data to assist in electricity management decision-making.

## Customizable Current Sensor and Voltage Sampling Method:

- Supports Rogowski coils and open-end CTs, with customizable current sensors.
- Different voltage sampling methods are available, including magnetic suction probes, voltage clamps, and piercing heads, among others.

## Connectable to MC Series Master Unit:

- The MC master unit supports customizable output protocols such as MQTT, Modbus RTU, and Modbus TCP.
- It can be connected to existing platforms via the MC series master unit for intuitive data viewing and parameter setting.

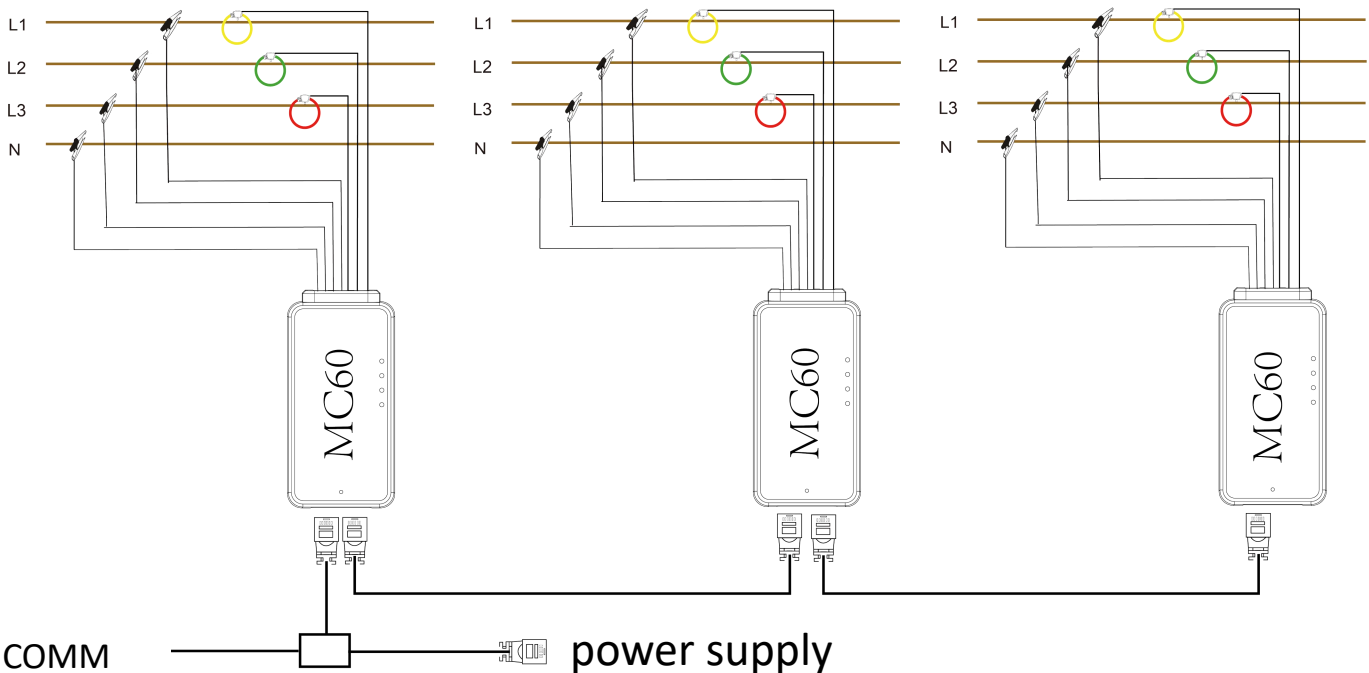

# Specifications

## Description

Mounting type	Multi-circuit
Model No.	MC60
Type of current sensor	Rogowski coilVoltage-output current transformer
Feature	Directly connect to Rogowski coil
Advantage	Wide current range, measurement without dismantling
Wiring system	3P4W_3CT, 3P3W_3CT, 3P3W_2CT, 1P3W, 1P2W
Application field	Power analysis and energy consumption monitoring
Display screen	None
Weight	59g
Dimension	L*W*D: 7.5*3.7*2.4CM
Color	Black

### Current measurement

Channel input voltage range	0-900mVAC peak, 636 mV RMS
Measurement range	Different current sensors have different measuring ranges
Rogowski coil	50mV/kA@50Hz (0-12000A), @60Hz (0-10000A) 85mV/kA@50Hz (0-7000A), @60Hz (0-6000A) 100mV/kA@50Hz (0-6000A), @60Hz (0-5000A)...
Voltage-output CT	0~99999A

### Voltage measurement

Measurement range	0~600VAC
Maximum measured value	720VAC

### Communication

RS485Communication	One RS485 communication interface Interface type: two-wire half-duplexCommunication baud rate: 2400bps~38400bpsProtocol: Modbus-RTU
--------------------	---

### Power supply

Power supply	MC60: 5VDC
Maximum power consumption	≤3.5VA

# Specifications

## Measurement parameters

	Argument	
Instantaneous value	Phase Voltage	U1, U2, U3, AVG, U0 (Zero sequence voltage)
	Line Voltage	U12, U23, U31, AVG
	Current	I1, I2, I3, AVG, In
	Grid frequency	F1, F2, F3, $\Sigma$
	Power factor PF	PF1, PF2, PF3, $\Sigma$
	Fundamental power factor DPF	DPF1, DPF2, DPF3, $\Sigma$
	Active power	P1, P2, P3, $\Sigma$
	Reactive power	Q1, Q2, Q3, $\Sigma$
	Apparent power	S1, S2, S3, $\Sigma$
Energy	Active energy Pos.	EP1, EP2, EP3, $\Sigma$
	Active Energy Neg.	EP1, EP2, EP3, $\Sigma$
	Reactive Energy Pos.	EQ1, EQ2, EQ3, $\Sigma$
	Reactive energy Neg.	EQ1, EQ2, EQ3, $\Sigma$
	Apparent Energy	ES1, ES2, ES3, $\Sigma$
		Tariff Energy
Harmonics	Voltage Harmonic Distortion	Total harmonic (U1, U2, U3)
		Odd total harmonic (U1, U2, U3)
		Even total harmonic (U1, U2, U3)
		Sub-harmonic1-50th (U1, U2, U3)
	Current Harmonic Distortion	Total harmonic (I1, I2, I3)
		Odd total harmonic (I1, I2, I3)
Even total harmonic (I1, I2, I3)		
K-factor (I1, I2, I3)		
Voltage Harmonic Value	Total harmonic (U1, U2, U3)	
	Sub-harmonic1-50th (U1, U2, U3)	
Current Harmonic Value	Total harmonic (I1, I2, I3)	
	Sub-harmonic1-50th (I1, I2, I3)	
Phase	Voltage Harmonic Distortion	Total harmonic (U1, U2, U3)
		Odd total harmonic (U1, U2, U3)
		Even total harmonic (U1, U2, U3)
		Sub-harmonic1-50th (U1, U2, U3)
	Current Harmonic Distortion	Total harmonic (I1, I2, I3)
		Odd total harmonic (I1, I2, I3)
Even total harmonic (I1, I2, I3)		
K-factor (I1, I2, I3)		
Voltage Harmonic Value	Total harmonic (U1, U2, U3)	
	Sub-harmonic1-50th (U1, U2, U3)	
Current Harmonic Value	Total harmonic (I1, I2, I3)	
	Sub-harmonic1-50th (I1, I2, I3)	

# Specifications

## Measurement parameters

	Argument	
Unbalance	Voltage unbalance	Negative Sequence, zero Sequence
	Current unbalance	Negative Sequence, zero Sequence
Max. & Min.	Phase Voltage	Each phase and average
	Line Voltage	Each phase and average
	Current	Each phase and average
	Active power	Each phase and total
	Reactive power	Each phase and total
	Apparent power	Each phase and total
Demand	Demand	Total active power, total reactive power, total apparent power
	Maximum demand of total active power	Maximum demand and time
	Maximum demand of total reactive power	Maximum demand and time
	Maximum demand of total apparent power	Maximum demand and time

# Specifications

## Accuracy and certification

	Argument	
Measurement Accuracy	Current measurement accuracy	0.1%
	Voltage measurement accuracy	$\pm 0.2\%$ (60V~600V AC)
	Grid frequency	$\pm 0.01\%$ (45~65Hz)
	Power factor	$\pm 0.005$
	Active and apparent power	IEC62053-22 class 0.5S
	Reactive power	IEC62053-21 class 1S
	Active energy	IEC62053-22 class 0.5S
	Reactive energy	IEC62053-21 class 1S
Environment condition	Operating temperature	-25°C~+70°C
	Storage temperature	-40°C~+85°C
	Humidity range	5~95% RH, 50°C (non-condensing)
	Class of pollution	2
	Overvoltage capacity	III, Applicable to power distribution system below 277/480VAC
	Insulation strength	IEC61010-1
	Altitude	3000m Max
	Anti-pollution grade	IP20 (Meet the standard of IEC 60629)
EMC (Electromagnetic compatibility)	Quality guarantee	12months
	Electrostatic discharge	Level IV (IEC61000-4-2)
	Radiated immunity	Level III (IEC61000-4-3)
	EFTElectrical fast burst immunity	Level IV (IEC61000-4-4)
	Surge immunity	Level IV (IEC61000-4-5)
	Conducted disturbance immunity	Level III (IEC61000-4-6)
	Power frequency magnetic field immunity	0.5mT (IEC61000-4-8)
	Conduction and radiation	Class B (EN55022 )
Measurement standard	EN 62052-11, EN61557-12, EN 62053-21, EN 62053-22, EN 62053-23, EN 50470-1, EN 50470-3, EN 61010-1, EN 61010-2, EN 61010-031	

# Specifications

## Input

### Current Input

Current	50mV/kA@50Hz (0-12000A), @60Hz (0-10000A)
Transformer Type	85mV/kA@50Hz (0-7000A), @60Hz (0-6000A)
	100mV/kA@50Hz (0-6000A), @60Hz (0-5000A)
	.....
Accuracy	0.5%



## Communication

### RS485

One RS485 communication interface  
Interface type: two-wire half-duplex  
Communication baud rate: 2400bps~38400bps  
Protocol: Modbus-RTU

## Power supply

### power

MC60 5VDC

# Appearance Parameters

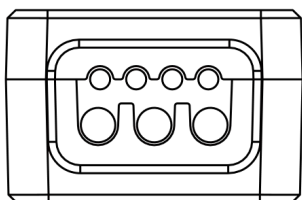
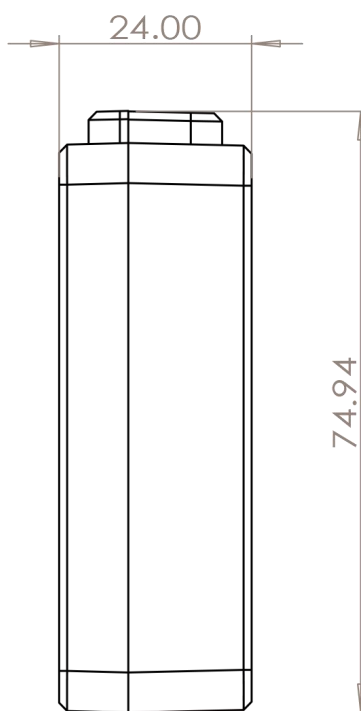
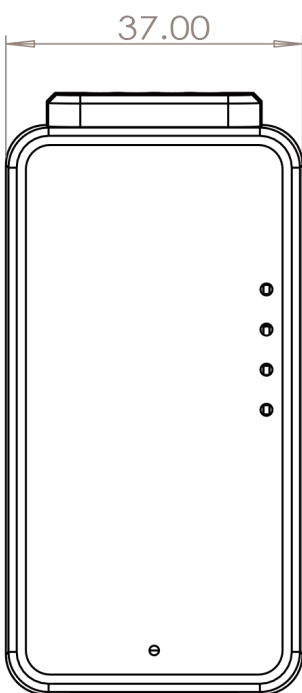
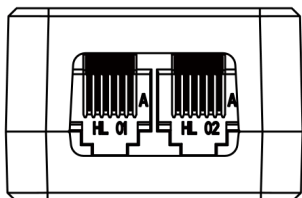
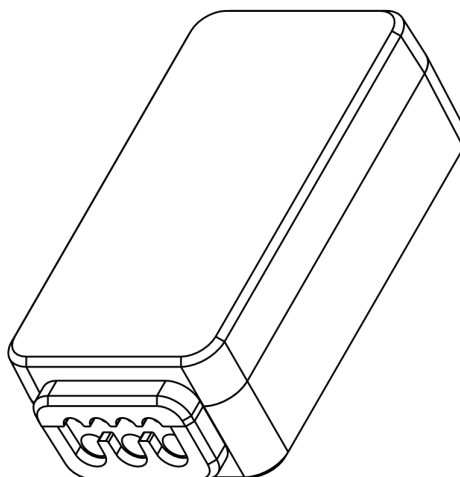



# Voltage and current wiring mode is as follows

Energy meter supports wiring mode, three-phase four-wire\_3CT(3P4W\_3CT), three-phase three-wire\_3CT(3P3W\_3CT), three-phase three-wire\_2CT(3P3W\_2CT), one-phase three-wire(1P3W), one phase and two-wire(1P2W)

- The actual wiring mode of the meter must be consistent with the wiring mode configured inside the meter.
- Three-phase four-wire 3CT (3P4W\_3CT) requires three current sensors, and the N-phase current is obtained through calculation.
- Three-phase three-wire 3CT (3P3W\_3CT) requires three current sensors, and phase B current is measured by the sensor.
- Three-phase three-wire 2CT (3P3W\_2CT) requires two current sensors, phase B current is obtained through calculation.
- The phase sequence of voltage and current must follow the phase sequence of L1L2L3, otherwise the meter will display voltage and current phase sequence error.
- When using the current sensor, note that the direction of the current arrow on the sensor must be consistent with the actual current direction, that is, the sensor current arrow points to the load end.

3P4W\_3CT

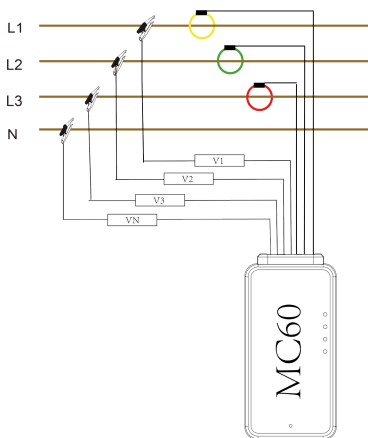

3P3W\_3CT

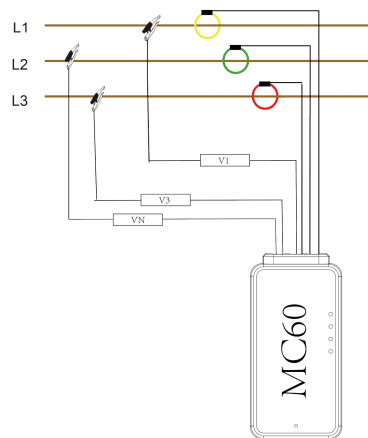

3P3W\_2CT

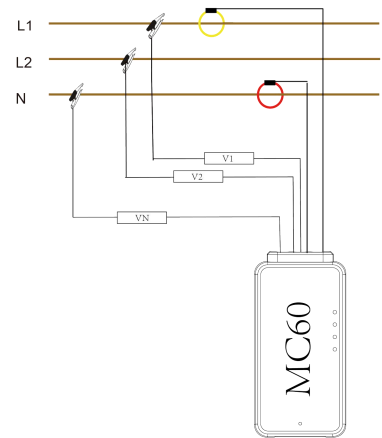

1P3W

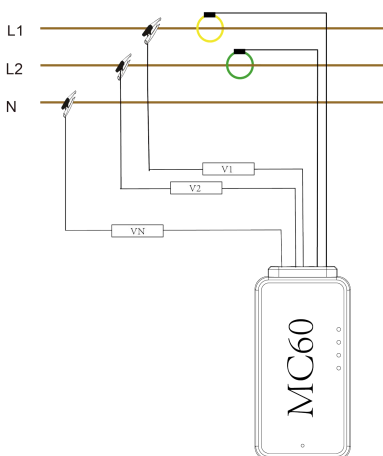

1P2W

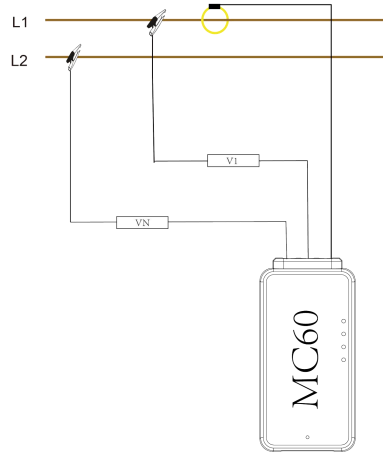

# Test version software

## Meter calibration

MC60 Test version of computer software

Calibration | Read data | SET | Description

Read meter parameters

Wiring mode:  Frequency (Hz):  Nominal voltage (V):  VT Ratio:  CT Ratio:

IABC sensor:  IABC Pri(A):  IABC Sec(mV):  IABC Range(A):

IN sensor:  IN Pri(A):  IN Sec(mV):  IN Range(A):

Write meter parameters

Grid parameters

Wiring mode:  Frequency:  Nominal voltage (V):  VT Ratio:  CT Ratio:

IABC

Sensor:  Rcoil Pri(A):  Rcoil Sec(mV)@50Hz:  Rcoil Range(A):  VCT Pri(A):  VCT Sec(mV):  VCT Range(A):

IN

Sensor:  Rcoil Pri(A):  Rcoil Sec(mV)@50Hz:  Rcoil Range(A):  VCT Pri(A):  VCT Sec(mV):  VCT Range(A):

Calibrate meter

Calibration value:  Calibration type:  Calibration phase:

## Electricity meter setting

MC60 Test version of computer software

Calibration | Read data | SET | Description

Communication parameter setting

Device address:  Baud rate:  Parity check:  Stop bit:

Product parameters

Model No.:  Serial No.:

Set time  Reset

Zero drift suppression  Set relay output

Voltage threshold:  Current threshold:    Close  Break off

Standard value

	Voltage	Current	PF	Active power	Reactive power	Apparent power	Frequency
Standard	<input type="text" value="220.0"/> V	<input type="text" value="200.0"/> A	<input type="text" value="0.500"/>	<input type="text" value="22.000"/> Kw	<input type="text" value="38.105"/> kVar	<input type="text" value="44.000"/> kVa	<input type="text" value="50.000"/> Hz
Error	<input type="text" value="0.200"/> %	<input type="text" value="0.500"/> %	<input type="text" value="0.005"/> %	<input type="text" value="0.500"/> %	<input type="text" value="0.500"/> %	<input type="text" value="0.500"/> %	<input type="text" value="0.005"/> Hz

# Function

## Multi tariff

Switching control mode of tariff	Description
Manual mode	Switch tariff through Modbus
RTC mode	Trigger tariff switching through RTC time period

### Manual control mode

The tariff can be switched through the configuration command 1071 of Modbus

### RTC control model

In RTC control mode, tariff switching is triggered by real-time clock. The RTC control mode supports 6 time periods (Ta, Tb, Tc, Td, Te, Tf) and 6 tariff (T1, T2, T3, T4, T5, T6). Any tariff can be specified for 6 time periods (Ta, Tb, Tc, Td, Te, Tf). The time period and target tariff can be modified through Modbus. The time period is set according to 24 hours, starting from the Ta starting time. The Tc starting time cannot be between the Ta starting time and the Tb starting time, and the Td starting time cannot be between the Ta starting time and the Tc starting time, and so on.

## Demand

Demand calculation method	Description
Fixed type	The meter will calculate and update the demand at the end of each interval
Sliding type	Update demand every 1 minute

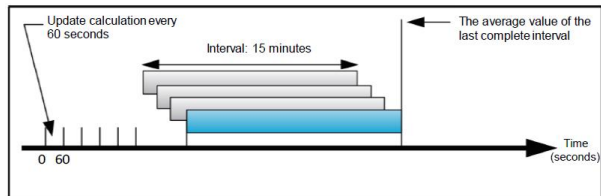

Sliding type

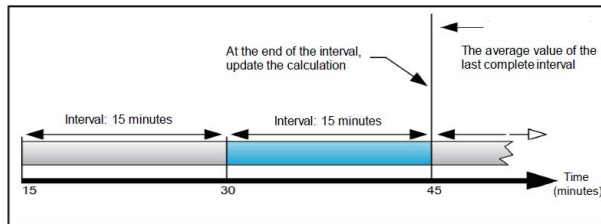

Fixed type

## Phase sequence detection

The meter supports three-phase voltage and current phase sequence detection, and can read the phase sequence status through Modbus.

**Note:** The correct phase sequence of voltage and current can only ensure the correct phase sequence of each, and cannot guarantee the corresponding relationship between voltage and current. Therefore, it is necessary to pay attention to the wiring mode.

# Modbus Communication

## Modbus-RTU Communication

Parameter	Effective value	Default
Address	1 - 247	1(via dial switch)
Baud rate	-1200-2400-4800-9600-19200-38400-57600-115200	9600
Data bits	8	8
Parity	- None - Odd - Even	None
Stop bit	1-2	1

## Modbus-RTU Data frame

Function code                                  Instructions

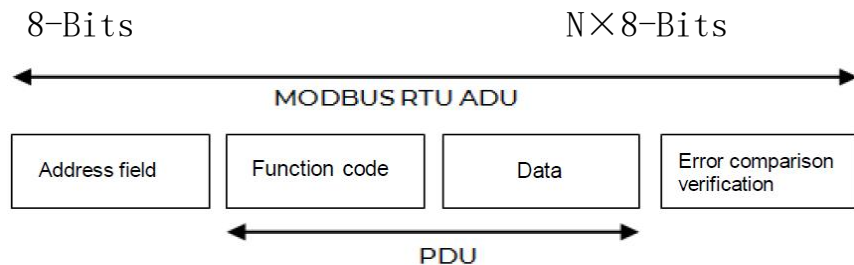

## Setting the device address

In the MC60 host computer testing software, the communication address of the MC60 can be set. Recognizable Modbus addresses range from 0 to 247, with 0 being the host recognition code. Setting the MC60 communication address to any value between 1 and 247 will be recognized.

Broadcast Address                                  Sub-node Address                                  Reserved Address

0	1 - 247	248-255
---	---------	---------

MC60 Test version of computer software

Calibration	Read data	SET	Description
Communication parameter setting			
Device address:	<input type="text" value="1"/>	Baud rate:	<input type="text" value="2400"/>
Parity check:	<input type="text" value="None"/>	Stop bit:	<input type="text" value="1bit"/>
<input type="button" value="Set communication parameters"/>			

# Function code

## Function code

Function code		Name of function code	Function
Decimal system	Hexadecimal		
3	03H	Read Holding Register	Used to read device parameters
16	10H	Write multiple registers	Used to configure device parameters

## Register list

- Register alias: It refers to the meaning of register.
- Register address: Address of Modbus data. The data address in this document is in decimal format.
- Operation: indicates the operation that the register can perform, R: read-only; W: Writable; WC: writable through instruction register.
- Size: Indicates the size of 16-bit data.
- Type: The type of data encoding.
- Unit: The unit of the register value.
- Description: Describe the function of this register.

## Data type list

Type	Description	Range
UInt16	Unsigned 16-bit integer	0 - 65535
Int16	Signed 16-bit integer	-32768 - +32767
UInt32	Unsigned 32-bit integer	0 - 4 294 967 295
UInt64	Unsigned 64-bit integer	0 - 18 446 744 073 709 551 615
UTF8	8-bit UTF code	Multibyte Unicode encoding
Float32	32-bit floating point	Standard IEEE floating point data (single precision)
Date Time	Date Time Type	-
Time	Time type	-

Date Time detailed explanation

Byte	Position														
	15	14	13	12	11	10	9	8	7	6	5	4	3	2	1
1	Year (2000 - 2099)														
2	Month(1 - 12)							Date(1 - 31)							
3	Hour (0 - 23)							Minute (0 - 59)							
4	Second(0 - 59)														

Time type details

Byte	Position														
	15	14	13	12	11	10	9	8	7	6	5	4	3	2	1
1	Hour(0 - 23)														
2	Minute(0 - 59)														
3	Second(0 - 59)														

## Configuration result

Register address	Content	Size (16 bits)	Data (example)
424	Configuration instruction code	1	1001(Set time)
425	Result	1	0 = Effective operation 80 = Invalid instruction code 81 = Invalid command parameter 82 = Numbersof invalid instruction parameters 83 = Operation not performed

Configure the device via Modbus-RTU.

You can use function code 16 to write instructions to the device and configure the device parameters. Device parameter configuration can only be configured by writing the corresponding data to the "configuration instruction register", that is, writing the corresponding data to the address starting from 300 to configure the corresponding parameters.

The configuration result can be read through registers 424 and 425.

# Modbus-RTU Function code operation instructions

## Function code (0x10=16)

### Request data format

SerialNo.	Name	Type	Range (Decimal system)	Description
1	Device address	UInt8	1-247	
2	Function code	UInt8	16	
3	Register start address	UInt16	-	High byte first (send order)
4	Number of registers	UInt16	1-123	High byte first (send order)
5	Number of register bytes	UInt8		Number of registers * 2
6	Write value of register 1	UInt16	-	High byte first (send order)
7	...	UInt16	-	High byte first (send order)
8	Write value of register n	UInt16	-	High byte first (send order)
9	CRC-16 check code	UInt16	-	Low byte first (send order)

### Return data format

SerialNo.	Name	Type	Range (Decimal system)	Description
1	Device address	UInt8	1-247	
2	Function code	UInt8	16	
3	Register start address	UInt16	300	High byte first
4	Number of registers	UInt16	1-123	High byte first
5	CRC-16 Check code	UInt16	-	Low byte first

### Attention!

Function code (0x10=16) can only write data to the "configuration instruction register", and can only write data to the register starting from address 300.

## Operation Example (0x10=16)

### Set Device Time (Command = 1200, Set to: 2022-11-1 12:20:00)

The order of sending bytes is as follows:

01 10 01 2C 00 07 0E 04 B0 07 E6 00 0B 00 01 00 0C 00 14 00 00 C4 8A

If the configuration data is correct, the following data will be returned:

01 10 01 2C 00 07 41 FE

Serial No.	Meaning	Type	Value (Decimal system)	Value (Hexadecimal)	Description
1	Device address	UInt8	1	01	
2	Function code	UInt8	16	10	
3	Register start address	UInt16	300	012C	Configuration register start address
4	Number of configuration registers	UInt16	7	0007	Configure timecommand+parameters 7 registers in total
5	Data length	UInt8	14	0E	Number of configuration registers * 2
6	Register 300 written value	UInt16	1200	04B0	Instruction code for configuring time1200
7	Register 301written value	UInt16	2022	07E6	Year=2022
8	Register 302written value	UInt16	11	000B	Month=11
9	Register 303written value	UInt16	1	0001	Date=1
10	Register 304written value	UInt16	12	000C	Hour=12
11	Register 305written value	UInt16	20	0014	Minute=20
12	Register 306 written value	UInt16	0	0000	Second=0
13	CRC-16 Check code	UInt16	35524	8AC4	Low byte first (send order)

Serial No.	Name	Type	Range (Hexadecimal)	Range (Decimal system)
1	Device address	UInt8	01	1
2	Function code	UInt8	10	16
3	Register start address	UInt16	012C	300
4	Number of registers	UInt16	0007	7
5	CRC-16 Check code	UInt16	41FE	

# Modbus-RTU Function code operation instructions

## Function code (0x03=3)

### Request data format

Serial No.	Name	Type	Range(Decimal system)	Description
1	Device address	UInt8	1-247	
2	Function code	UInt8	3	
3	Start register address	UInt16	-	High byte first (send order)
4	Number of registers	UInt16	1-125	High byte first (send order)
5	CRC-16check	UInt16	-	Low byte first (send order)

### Return data format

Serial No.	Name	Type	Range(Decimal system)	Description
1	Device address	UInt8	1-247	
2	Function code	UInt8	3	
3	Read register bytes	UInt8	-	Number of read registers * 2
4	Value of register 1		-	High byte first
5	...		-	High byte first
6	Value of register n		-	High byte first
7	CRC-16 check	UInt16	-	Low byte first

## Operation Example (0x03=3)

Read the voltage values of L1, L2 and L3 (the starting address of voltage register is: 1010):

The order of sending bytes is as follows:

01 03 03 F2 00 06 64 7F

Return data:

01 03 0C 43 5C 00 00 43 5D 00 00 43 5E 00 00 14 AC

Serial No.	Name	Type	Range(Decimal system)	Range(Hexadecimal)	Description
1	Device address	UInt8	1	0x01	
2	Function code	UInt8	3	0x03	
3	Start register address	UInt16	1010	0x03F2	
4	Number of registers	UInt16	6	0x0006	
5	CRC-16check	UInt16	32612	0x7F64	Low byte first (send order)



Serial No.	Name	Type	Hexadecimal	Decimal system
1	Device address	UInt8	01	1
2	Function code	UInt8	03	3
3	Read register bytes	UInt8	0C	12
4	Phase L1 voltage	float 32	435C0000	220V
5	Phase L2 voltage	float 32	435D0000	221V
6	Phase L3 voltage	float 32	435E0000	222V
7	CRC-16 check	UInt16	14AC	

# Error response

## Error response data

Serial No.	Name	Type	Decimal system	Hexadecimal	Remark
1	Device address	UInt8	1-247	0x01-0xF7	
2	Function code	UInt8	(128+3) (128+16)	(0x80+0x03) (0x80+0x10)	
3	Error code	UInt8			
4	CRC-16check	UInt16			Low byte first

## Modbus Error code

Code	Name	Meaning
0x01	Illegal function code	The function code 3 or 16 supported by the device is not used
0x02	Illegal data address	The register data written or read is not within the address range supported by the device
0x03	Illegal data value	The data value written to the register does not meet the requirements
0x04	Equipment error	An unknown error occurred



# List of configuration instructions

## System parameter setting

Instruction code	Operation	Size	Type	Unit	Range (Decimal system)	Description
1001	W	1	UInt16	-	1, 2, 3, 4, 5	Wiring mode 1=3P4W_3CT 2=3P3W_3CT 3=3P3W_2CT 4=1P3W 5=1P2W
	W	1	UInt16	Hz	50, 60	Grid frequency
	W	1	UInt16	V	1-65535	Nominal voltage (excluding VT ratio)
	W	2	UInt32	-	1-99999999	VT transformation ratio, amplification 10000 times
	W	2	UInt32	-	1-99999999	CT transformation ratio, magnification 10000 times

## Parameter setting of phase L1L2L3 current transformer

Instruction code	Operation	Size	Type	Unit	Range (Decimal system)	Description
1002	W	1	UInt16	-	0, 1	PhaseL1L2L3current access mode 0 =Rogowski coil input 1 = VCTinput
	W	2	UInt32	A	1-999999	Phase L1L2L3 Rogowski coil input value
	W	2	UInt32	mV@50HzmV@60Hz	1-99999	Phase L1L2L3 Rogowski coil output value=Actual value*100 (Note: the output shall be set according to the gridfrequency)
	W	2	UInt32	A	1-999999	PhaseL1L2L3Rogowskicoil nominal current
	W	2	UInt32	A	1-999999	PHASE L1L2L3VCTinput value
	W	2	UInt32	mV	1-99999	PHASE L1L2L3VCToutput value=Actual value*100
	W	2	UInt32	A	1-999999	PHASE L1L2L3VCTnominal current

## Parameter setting of N-phase current transformer

Instruction code	Operation	Size	Type	Unit	Range (Decimal system)	Description
1003	W	1	UInt16	-	0, 1	N-phase current access mode 0 = Rogowski coil input 1 = VCTinput
	W	2	UInt32	A	1-999999	N-phase Rogowski coil input value
	W	2	UInt32	mV@50Hz mV@60Hz	1-99999	N-phase Rogowski coil output value=Actual value*100 (Note: the output shall be set according to the grid frequency)
	W	2	UInt32	A	1-999999	N-phase Rogowski coil nominal current
	W	2	UInt32	A	1-999999	N-phase VCTinput value
	W	2	UInt32	mV	1-99999	N-phase VCToutput value=Actual value*100
	W	2	UInt32	A	1-999999	N-phase VCTnominal current

# List of configuration instructions

## Phase L1L2L3 Current direction setting

Instruction code	Operation	Size	Type	Unit	Range(Decimal system)	Description
1010	W	1	UInt16	-	0, 1	Phase L1 current direction 0 = Positive (default) 1 =Reverse
	W	1	UInt16	-	0, 1	L2 current direction 0 = Positive (default) 1 = Reverse
	W	1	UInt16	-	0, 1	L3 current direction 0 = Positive (default) 1 = Reverse

This configuration can be used to modify the current direction when the coil direction is inconsistent with the actual one.

## Phase L1L2L3 Current channel setting

Instruction code	Operation	Size	Type	Unit	Range(Decimal system)	Description
1011	W	1	UInt16	-	0, 1, 2	L1 current channel selection 0 = Current channel 1 (default) 1 = Current channel2 2 = Current channel 3
	W	1	UInt16	-	0, 1, 2	L2 current channel selection 0 = Current channel 1 1 = Current channel 2(default) 2 = Current channel 3
	W	1	UInt16	-	0, 1, 2	L3 current channel selection 0 = Current channel 1 1 = Current channel 2 2 = Current channel 3(default)

When the current and voltage do not correspond, you can use this configuration to modify the current channel selection so that the current and voltage correspond to each phase.

## Zero drift suppression setting

Instruction code	Operation	Size	Type	Unit	Range(Decimal system)	Description
1020	W	1	UInt16	%	0~1000	Voltage zero drift suppression takes (nominal voltage * VT ratio) as reference= Actual value *100Default: 10
	W	1	UInt16	%	0~1000	Current zero drift suppression takes (nominal current * CT ratio) as reference.=Actual value*100Default: 10

## Demand parameter setting

Instruction code	Operation	Size	Type	Unit	Range(Decimal system)	Description
1060	W	1	UInt16	-	0, 1	Demand calculation method 0 = Fixed type 1 = Sliding type
	W	1	UInt16	Minute	1-60	Demand calculation interval

# List of configuration instructions

## Tariff mode setting

Instruction code	Operation	Size	Type	Unit	Range(Decimal system)	Description
1070	W	1	UInt16	-	0,1	Tariff switching mode 0 = Manual switching 1= RTC switching

## Manual tariff setting

Instruction code	Operation	Size	Type	Unit	Range(Decimal system)	Description
1071	W	1	UInt16	-	0-5	Manual tariff setting 0 = tariff 1 1 = tariff 2 ... 5 = tariff 6 (Note: this setting is only valid when the tariff mode is manual switching)

## RTC Tariff time period setting

Instruction code	Operation	Size	Type	Unit	Range(Decimal system)	Description
1072	W	3	Time	-	-	TaStart time
	W	3	Time	-	-	TbStart time
	W	3	Time	-	-	Tc Start time
	W	3	Time	-	-	Td Start time
	W	3	Time	-	-	Te Start time
	W	3	Time	-	-	Tf Start time

## RTC Tariff selection setting

Instruction code	Operation	Size	Type	Unit	Range(Decimal system)	Description
1073	W	1	UInt16	-	0-5	Ta Tariff setting 0 = Tariff 1 1 = Tariff 2 ... 5= Tariff 6
	W	1	UInt16	-	0-5	Tb Tariff setting
	W	1	UInt16	-	0-5	Tc Tariff setting
	W	1	UInt16	-	0-5	Td Tariff setting
	W	1	UInt16	-	0-5	Te Tariff setting
	W	1	UInt16	-	0-5	Tf Tariff setting

# List of configuration instructions

## Equipment time setting

Instruction code	Operation	Size	Type	Unit	Range (Decimal system)	Description
1200	W	1	UInt16	-	2000-2099	Year
	W	1	UInt16	-	1-12	Month
	W	1	UInt16	-	1-31	Date
	W	1	UInt16	-	0-23	Hour
	W	1	UInt16	-	0-59	Minute
	W	1	UInt16	-	0-59	Second

## Communication parameter setting

Instruction code	Operation	Size	Type	Unit	Range (Decimal system)	Description
1210	W	1	UInt16	-	1-247	Slave address
	W	1	UInt16	-	0-6	Baud rate 0 = 2400 1 = 4800 2 = 9600 3 = 19200 4 = 38400 5 = 57600 6 = 115200
	W	1	UInt16	-	0, 1, 2	Parity check 0 = None 1 = Odd 2 = Even
	W	1	UInt16	-	1, 2	Stop bit 1 = 1bit 2 = 2bits

## Reset

Instruction code	Operation	Size	Type	Unit	Range (Decimal system)	Description
1301	W	1	UInt16	-	1-5	1: Reset Max & Minvalue 2: Reset Max demand 3: Reset tariff energy 4: Reset energy 5: Reset all above values

# Register list

## Register list

- Register alias: Used to refer to the meaning of register
- Register address: The starting address of the modbus communication register. It is in decimal format, and the address is the real address without offset.
- Operation: Indicate the operations that the register can do. R: Readable; W: Can be written directly through 16 function codes; WC: The current register needs to be configured indirectly by writing configuration data to the address starting from instruction register 300
- Size: Indicates how many modbus registers are occupied. One modbus register is 16bit
- Type: Refer to the data type table for the type of data code
- Unit: Unit of register value
- Description: Describe the function of this register

## Data type table

Type	Description	Range
UInt16	Unsigned 16-bit integer	0~65535
Int16	Signed 16-bit integer	-32768~+32767
UInt32	Unsigned 32-bit integer	0~4294967295
UInt64	Unsigned 64-bit integer	0~18446744073709551615
Int64	Signed 64-bit integer	-9223372036854775808 ~ 9223372036854775808
UTF8	8-bit UTF code	Multibyte Unicode encoding
Float32	32-bit floating point	Standard IEEE floating point data (single precision)
Date Time	Time type	-

Date Time  
format

Byte	Position														
	15	14	13	12	11	10	9	8	7	6	5	4	3	2	1
1	Year (2000 - 2099)														
2	Month(1 - 12)							Date(1 - 31)							
3	Hour(0 - 23)							Minute(0 - 59)							
4	Second(0 - 60)														

# Modbus Register List

## Equipment parameters

Register alias	Register start address (Decimal system)	OperationRead/Write	Size	Type	Unit	Description
Equipment model	60	R	10	UTF8	-	
SerialNo.	70	R	2	UInt32	-	
APPVersionNo.	72	R	1	UInt16	-	Format: X.Y
Date and time	75	R/WC	4	Date time	-	Reg. 75: Year 2000-2099 Reg. 76: Month(b15:b8), Date (b7:b0) Reg. 77: Hour (b15:b8), Minute (b7:b0) Reg. 78: Second

## Communication parameters

Register alias	Register start address (Decimal system)	OperationRead/Write	Size	Type	Unit	Description
Slave address	80	R/WC	1	UInt16	-	1-247
Baud rate	81	R/WC	1	UInt16	-	0 = 2400 1 = 4800 2 = 9600 3 = 19200 4 = 38400 5 = 57600 6 = 115200
Verification method	82	R/WC	1	UInt16	-	0 = No verification 1 = Odd check 2 = Even check
Stop bit	83	R/WC	1	UInt16	-	1 = 1 bit2 = 2 bits

## Voltage and current phase

Register alias	Register start address (Decimal system)	OperationRead/Write	Size	Type	Unit	Description
Voltage and current phase sequence	220	R	1	UInt16	-	0 =Voltage phase sequencecorrect, Current phase sequencecorrect 1 =Voltage phase sequence error,Current phase sequencecorrect 2 =Voltage phase sequence correct, Current phase sequence error 3 =Voltage phase sequence error,Current phase sequence error

## Configure instruction register

Register alias	Register start address (Decimal system)	OperationRead/Write	Size	Type	Unit	Description
Instruction code	300	R/W	1	UInt16	-	
Command parameters 001	301	R/W	1	UInt16	-	
Command parameters002	302	R/W	1	UInt16	-	
...	...	R/W	1	UInt16	-	
Command parameters 123	423	R/W	1	UInt16	-	
Configuration instruction code	424	R	1	UInt16	-	
Configuration results	425	R	1	UInt16	-	0 = Effective operation 80 = Invalid instruction code 81 = Invalid command parameter 82 = Number of invalid instruction parameters 83= Operation not performed

# Modbus Register List

## Power system parameters

Register alias	Register start address (Decimal system)	OperationRead/Write	Size	Type	Unit	Description
Wiring mode	500	R/WC	1	UInt16	-	0= Three-phase four-wire 4CT 1= Three-phase four-wire 3CT 2= Three-phase three-wire 3CT 3= Three-phase three-wire 2CT 4= One-phase three-wire 5= One phase and two-wire
Grid frequency	501	R/WC	1	UInt16	Hz	
Nominal voltage	502	R/WC	1	UInt16	V	Excluding VT ratio
VTRatio	503	R/WC	2	UInt32	-	Actual value=Read value/10000
CTRatio	505	R/WC	2	UInt32	-	Actual value=Read value/10000
PHASE L1L2L3Current transformer						
PHASE L1L2L3 Current access mode	510	R/WC	1	UInt16	-	0 = Rogowski coil1 = VCT
PHASE L1L2L3 Rogowski coilPri	511	R/WC	2	UInt32	A	
PHASE L1L2L3Rogowski coilSec	513	R/WC	2	UInt32	mV@50HzmV@60Hz	Actual value=Read value/100
PHASE L1L2L3Rogowski coilNominal current	515	R/WC	2	UInt32	A	
PHASE L1L2L3VCT Pri	517	R/WC	2	UInt32	A	
PHASE L1L2L3VCT Sec	519	R/WC	2	UInt32	mV	Actual value=Read value/100
PHASE L1L2L3VCTNominal current	521	R/WC	2	UInt32	A	
N-phaseCurrent transformer						
N-phaseCurrent access mode	530	R/WC	1	UInt16	-	0 = Rogowski coil1 = CT
N-phase Rogowski coil Pri	531	R/WC	2	UInt32	A	
N-phaseRogowski coil Sec	533	R/WC	2	UInt32	mV@50HzmV@60Hz	Actual value=Read value/100
N-phaseRogowski coilNominal current	535	R/WC	2	UInt32	A	
N-phaseVCT Pri	537	R/WC	2	UInt32	A	
N-phaseVCT Sec	539	R/WC	2	UInt32	mV	Actual value=Read value/100
N-phaseVCTNominal current	541	R/WC	2	UInt32	A	

# Modbus Register List

## Current direction setting

Register alias	Register start address (Decimal system)	OperationRead/Write	Size	Type	Unit	Description
Phase L1 current direction	550	R/WC	1	UInt16	-	Phase L1 current direction 0=Positive (default) 1=Reverse
Phase L2 current direction	551	R/WC	1	UInt16	-	Phase L2 current direction 0=Positive (default) 1=Reverse
Phase L3 current direction	552	R/WC	1	UInt16	-	Phase L3 current direction 0=Positive (default) 1=Reverse

## Current channel selection

Register alias	Register start address (Decimal system)	OperationRead/Write	Size	Type	Unit	Description
Phase L1 current channel	553	R/WC	1	UInt16	-	Phase L1 current channel 0=Channel 1 (Default) 1=Channel 2 2=Channel 3
Phase L2 current channel	554	R/WC	1	UInt16	-	Phase L2 current channel 0=Channel 1 1=Channel 2 (Default) 2=Channel 3
Phase L3 current channel	555	R/WC	1	UInt16	-	Phase L3 current channel 0=Channel 1 1=Channel 2 2=Channel 3 (Default)

## Zero drift suppression parameters

Register alias	Register start address (Decimal system)	OperationRead/Write	Size	Type	Unit	Description
Voltage zero drift suppression	600	R/WC	1	UInt16	%	Voltage zero drift suppression takes (nominal voltage * VT ratio) as referenceActual value=Read value/100
Current zero drift suppression	601	R/WC	1	UInt16	%	Current zero drift suppression takes (nominal current * CT ratio) as referenceActual value=Read value/100



# Modbus Register List

## Tariff parameters

Register alias	Register start address (Decimal system)	OperationRead/W rite	Size	Type	Unit	Description
Current tariff	800	R	1	UInt16	-	Current tariff 0-5=tariff 1-tariff 6
Tariff switching mode	801	R/WC	1	UInt16	-	Tariff switching mode 0= Manual switching 1=RTCswitching
Manual tariffselection	802	R/WC	1	UInt16	-	Manual tariffselection 0-5=Tariff 1-Tariff 6
RTC Ta Start time	803	R/WC	3	Time	-	RTC Ta Start time
RTC Tb Start time	806	R/WC	3	Time	-	RTC Tb Start time
RTC Tc Start time	809	R/WC	3	Time	-	RTC Tc Start time
RTC Td Start time	812	R/WC	3	Time	-	RTC Td Start time
RTC Te Start time	815	R/WC	3	Time	-	RTC Te Start time
RTC Tf Start time	818	R/WC	3	Time	-	RTC Tf Start time
RTC Ta tariff selection	821	R/WC	1	UInt16	-	Tatariff selection 0-5=Tariff 1-Tariff 6
RTC Tb tariff selection	822	R/WC	1	UInt16	-	Tbtariff selection 0-5=Tariff 1-Tariff 6
RTC Tc tariff selection	823	R/WC	1	UInt16	-	Tctariff selection 0-5=Tariff 1-Tariff 6
RTC Td tariff selection	824	R/WC	1	UInt16	-	Tdtariff selection 0-5=Tariff 1-Tariff 6
RTC Te tariff selection	825	R/WC	1	UInt16	-	Tetariff selection 0-5=Tariff 1-Tariff 6
RTC Tf tariff selection	826	R/WC	1	UInt16	-	Tftariff selection 0-5=Tariff 1-Tariff 6

## Tariff energy

Register alias	Register start address (Decimal system)	OperationRead/Wri te	Size	Type	Unit	Description
Tariff energy-Int64						
ET1	2700	R	4	Int64	Wh	Tariff 1 Active energy
ET2	2704	R	4	Int64	Wh	Tariff 2 Active energy
ET3	2708	R	4	Int64	Wh	Tariff 3 Active energy
ET4	2712	R	4	Int64	Wh	Tariff 4 Active energy
ET5	2716	R	4	Int64	Wh	Tariff 5 Active energy
ET6	2720	R	4	Int64	Wh	Tariff 6 Active energy
Tariff energy-UInt32						
ET1	2750	R	2	UInt32	kWh	Tariff 1 Active energy
ET2	2752	R	2	UInt32	kWh	Tariff 2 Active energy
ET3	2754	R	2	UInt32	kWh	Tariff 3 Active energy
ET4	2756	R	2	UInt32	kWh	Tariff 4 Active energy
ET5	2758	R	2	UInt32	kWh	Tariff 5 Active energy

There are two types of tariff energy data: Int64 and UInt32, with different unit sizes. When the tariff energy reaches  $1.0 \times 10^9$  kWh kWh, each tariff energy will be automatically reset.

# Modbus Register List

## Voltage, current, power and power factor

Register alias	Register start address (Decimal system)	OperationRead/W rite	Size	Type	Unit	Description
<b>Current</b>						
IA	1000	R	2	Float32	A	PhaseL1 Current
IB	1002	R	2	Float32	A	PhaseL2 Current
IC	1004	R	2	Float32	A	PhaseL3 Current
Current Avg	1006	R	2	Float32	A	Average value of three-phase current, L1L2L3
IN	1008	R	2	Float32	A	N-phase Current
<b>Phase voltage</b>						
UA	1010	R	2	Float32	V	UA-UN voltage
UB	1012	R	2	Float32	V	UB-UN voltage
UC	1014	R	2	Float32	V	UC-UN voltage
Phase Voltage Avg	1016	R	2	Float32	V	Average value of three-phase phase voltage, L1L2L3
U0	1018	R	2	Float32	V	Zero sequence voltage
<b>Line voltage</b>						
UAB	1020	R	2	Float32	V	UA-UBvoltage
UBC	1022	R	2	Float32	V	UB-UCvoltage
UCA	1024	R	2	Float32	V	UC-UA voltage
Line Voltage Avg	1026	R	2	Float32	V	Average value of three-phase line voltage
<b>Active power</b>						
PA	1028	R	2	Float32	kW	PhaseL1 Active power
PB	1030	R	2	Float32	kW	PhaseL2 Active power
PC	1032	R	2	Float32	kW	PhaseL3 Active power
PTotal	1034	R	2	Float32	kW	Total active power
<b>Reactive power</b>						
QA	1036	R	2	Float32	kVAR	PhaseL1 Reactive power
QB	1038	R	2	Float32	kVAR	PhaseL2 Reactive power
QC	1040	R	2	Float32	kVAR	PhaseL3 Reactive power
QTotal	1042	R	2	Float32	kVAR	Total reactive power
<b>Apparent power</b>						
SA	1044	R	2	Float32	kVA	PhaseL1 Apparent power
SB	1046	R	2	Float32	kVA	PhaseL2 Apparent power
SC	1048	R	2	Float32	kVA	PhaseL3 Apparent power
STotal	1050	R	2	Float32	kVA	Total apparent power
<b>Power factor</b>						
PFA	1052	R	2	Float32	-	PhaseL1 Power factor
PFB	1054	R	2	Float32	-	PhaseL2 Power factor
PFC	1056	R	2	Float32	-	PhaseL3 Power factor
PFTotal	1058	R	2	Float32	-	Total power factor
<b>Fundamental power factor</b>						
DPFA	1060	R	2	Float32	-	PhaseL1 Fundamental power factor
DPFB	1062	R	2	Float32	-	PhaseL2 Fundamental power factor
DPFC	1064	R	2	Float32	-	PhaseL3 Fundamental power factor
DPFTotal	1066	R	2	Float32	-	Total fundamental power factor
<b>Frequency</b>						
FreqA	1068	R	2	Float32	Hz	PhaseL1 Frequency
FreqB	1070	R	2	Float32	Hz	PhaseL2 Frequency
FreqC	1072	R	2	Float32	Hz	PhaseL3 Frequency
FreqTotal	1074	R	2	Float32	Hz	Three-phase integrated frequency

# Modbus Register List

## Electric energy

Register alias	Register start address (Decimal system)	Operation	Read/Write	Size	Type	Unit	Description
Active energy-Int64							
EPAImp	2500	R		4	Int64	Wh	PhaseL1 Positive active energy
EPBImp	2504	R		4	Int64	Wh	PhaseL2 Positive active energy
EPCImp	2508	R		4	Int64	Wh	PhaseL3 Positive active energy
EPImp	2512	R		4	Int64	Wh	Total positive active energy
EPAExp	2516	R		4	Int64	Wh	PhaseL1 Reverse active energy
EPBExp	2520	R		4	Int64	Wh	PhaseL2 Reverse active energy
EPCExp	2524	R		4	Int64	Wh	PhaseL3 Reverse active energy
EPExp	2528	R		4	Int64	Wh	Total reverse active energy
Reactive energy-Int64							
EQAImp	2532	R		4	Int64	VARh	PhaseL1 Positive reactive energy
EQBImp	2536	R		4	Int64	VARh	PhaseL2 Positive reactive energy
EQCImp	2540	R		4	Int64	VARh	PhaseL3 Positive reactive energy
EQImp	2544	R		4	Int64	VARh	Total positive reactive energy
EQAExp	2548	R		4	Int64	VARh	PhaseL1 Reverse reactive energy
EQBExp	2552	R		4	Int64	VARh	PhaseL2 Reverse reactive energy
EQCExp	2556	R		4	Int64	VARh	PhaseL3 Reverse reactive energy
EQExp	2560	R		4	Int64	VARh	Total Reverse reactive energy
Apparent energy-Int64							
ESA	2564	R		4	Int64	VAh	Phase L1 Apparent energy
ESB	2568	R		4	Int64	VAh	PhaseL2 Apparent energy
ESC	2572	R		4	Int64	VAh	PhaseL3 Apparent energy
ES	2576	R		4	Int64	VAh	Total apparent energy
UInt32 Energy							
Active energy-UInt32							
EPAImp	2600	R		2	UInt32	kWh	PhaseL1 Positive active energy
EPBImp	2602	R		2	UInt32	kWh	PhaseL2 Positive active energy
EPCImp	2604	R		2	UInt32	kWh	PhaseL3 Positive active energy
EPImp	2606	R		2	UInt32	kWh	Total positive active energy
EPAExp	2608	R		2	UInt32	kWh	PhaseL1 Reverse active energy
EPBExp	2610	R		2	UInt32	kWh	PhaseL2 Reverse active energy
EPCExp	2612	R		2	UInt32	kWh	PhaseL3 Reverse active energy
EPExp	2614	R		2	UInt32	kWh	Total reverse active energy
Reactive energy-UInt32							
EQAImp	2616	R		2	UInt32	kVARh	PhaseL1 Positive reactive energy
EQBImp	2618	R		2	UInt32	kVARh	PhaseL2 Positive reactive energy
EQCImp	2620	R		2	UInt32	kVARh	PhaseL3 Positive reactive energy
EQImp	2622	R		2	UInt32	kVARh	Total positive reactive energy
EQAExp	2624	R		2	UInt32	kVARh	PhaseL1 Reverse reactive energy
EQBExp	2626	R		2	UInt32	kVARh	PhaseL2 Reverse reactive energy
EQCExp	2628	R		2	UInt32	kVARh	PhaseL3 Reverse reactive energy
EQExp	2630	R		2	UInt32	kVARh	Total reverse reactive energy
Apparent energy-UInt32							
ESA	2632	R		2	UInt32	kVAh	PhaseL1 Apparent energy
ESB	2634	R		2	UInt32	kVAh	PhaseL2 Apparent energy
ESC	2636	R		2	UInt32	kVAh	PhaseL3 Apparent energy
ES	2638	R		2	UInt32	kVAh	Total apparent energy

# Modbus Register List

## Demand parameters

Register alias	Register start address(Decimal system)	OperationRead/Write	Size	Type	Unit	Description
<b>Basic parameters of demand</b>						
DMDMethod	3000	R/WC	1	UInt16	-	Demand calculation method:0=Sliding type1=Fixed type
DMD block	3001	R/RC	1	UInt16	Minute	Demand interval
PDMD Reset Time	3002	R	4	Date time	-	Max demand reset date and time
<b>Power demand</b>						
PADemand	3020	R	2	Float32	kW	PhaseL1 Current active power demand
PAPeakDemand	3022	R	2	Float32	kW	PhaseL1 Max demand of active power
PAPeakDemandDate	3024	R	4	Date time	-	PhaseL1 Time of occurrencefor Max demand of active power
PBDemand	3028	R	2	Float32	kW	PhaseL2 Current active power demand
PBPeakDemand	3030	R	2	Float32	kW	PhaseL2 Max demand of active power
PBPeakDemandDate	3032	R	4	Date time	-	PhaseL2 Occurrence time of max active power demand
PCDemand	3036	R	2	Float32	kW	PhaseL3 Current active power demand
PCPeakDemand	3038	R	2	Float32	kW	PhaseL3 Max demand of active power
PCPeakDemandDate	3040	R	4	Date time	-	PhaseL3 Occurrence time of max active power demand
PSUMDemand	3044	R	2	Float32	kW	Current total active power demand
PSUMPeakDemand	3046	R	2	Float32	kW	Total maxactive power demand
PSUMPeakDemandDate	3048	R	4	Date time	-	Occurrence time of total max active power demand
QADemand	3052	R	2	Float32	kVar	PhaseL1 Current reactive power demand
QAPeakDemand	3054	R	2	Float32	kVar	PhaseL1 Max demand of reactive power
QAPeakDemandDate	3056	R	4	Date time	-	PhaseL1 Occurrence time of max reactive power demand
QBDemand	3060	R	2	Float32	kVar	PhaseL2 Current reactive power demand
QBPeakDemand	3062	R	2	Float32	kVar	PhaseL2 Max demand of reactive power
QBPeakDemandDate	3064	R	4	Date time	-	PhaseL2 Occurrence time of max reactive power demand
QCDemand	3068	R	2	Float32	kVar	PhaseL3 Current reactive power demand
QCPeakDemand	3070	R	2	Float32	kVar	PhaseL3 Max demand of reactive power
QCPeakDemandDate	3072	R	4	Date time	-	PhaseL3 Occurrence time of max reactive power demand
QSUMDemand	3076	R	2	Float32	kVar	Current total reactive power demand
QSUMPeakDemand	3078	R	2	Float32	kVar	Max demand of total reactive power
QSUMPeakDemandDate	3080	R	4	Date time	-	Occurrence time of total max reactive power demand
SADemand	3084	R	2	Float32	kVa	PhaseL1 Current apparent power demand
SAPeakDemand	3086	R	2	Float32	kVa	PhaseL1 Max apparent power demand
SAPeakDemandDate	3088	R	4	Date time	-	PhaseL1 Occurrence time of max apparent power demand
SBDemand	3092	R	2	Float32	kVa	PhaseL2 Current apparent power demand
SBPeakDemand	3094	R	2	Float32	kVa	PhaseL2 Max apparent power demand
SBPeakDemandDate	3096	R	4	Date time	-	PhaseL2 Occurrence time of max apparent power demand
SCDemand	3100	R	2	Float32	kVa	PhaseL3 Current apparent power demand
SCPeakDemand	3102	R	2	Float32	kVa	PhaseL3 Max apparent power demand
SCPeakDemandDate	3104	R	4	Date time	-	PhaseL3 Occurrence time of max apparent power demand
SSUMDemand	3108	R	2	Float32	kVa	Current total apparent power demand
SSUMPeakDemand	3110	R	2	Float32	kVa	Total of max apparent power demand
SSUMPeakDemandDate	3112	R	4	Date time	-	Occurrence time of total max apparent power demand

# Voltage and current harmonics

Register name	Register start address (Decimal system)	Operation	Size	Type	Unit	Description
Current harmonic percentage						
IATHD	4000	R	2	Float32	%	Phase L1 current: Percentage of total harmonic
IBTHD	4002	R	2	Float32	%	Phase L2 current: Percentage of total harmonic
ICTHD	4004	R	2	Float32	%	Phase L3 current: Percentage of total harmonic
IATOHD	4006	R	2	Float32	%	Phase L1 current: Odd total harmonic percentage
IBTOHD	4008	R	2	Float32	%	Phase L2 current: Odd total harmonic percentage
ICTOHD	4010	R	2	Float32	%	Phase L3 current: Odd total harmonic percentage
IATEHD	4012	R	2	Float32	%	Phase L1 current: Even total harmonic percentage
IBTEHD	4014	R	2	Float32	%	Phase L2 current: Even total harmonic percentage
ICTEHD	4016	R	2	Float32	%	Phase L3 current: Even total harmonic percentage
IAHD1	4018	R	2	Float32	%	Phase L1 current: 1st harmonic percentage
IBHD1	4020	R	2	Float32	%	Phase L2 current: 1st harmonic percentage
ICHD1	4022	R	2	Float32	%	Phase L3 current: 1st harmonic percentage
...	4024-4311	...	...	...	...	Phase L1L2L3 current: 2nd-49th harmonic percentage
IAHD50	4312	R	2	Float32	%	Phase L1 current: 50th harmonic percentage
IBHD50	4314	R	2	Float32	%	Phase L2 current: 50th harmonic percentage
ICHD50	4316	R	2	Float32	%	Phase L3 current: 50th harmonic percentage
Current harmonic value						
IAHDV1	4400	R	2	Float32	A	Phase L1 current: Fundamental current value
IBHDV1	4402	R	2	Float32	A	Phase L2 current: Fundamental current value
ICHDV1	4404	R	2	Float32	A	Phase L3 current: Fundamental current value
...	4406-4693	...	...	...	...	Phase L1L2L3 current: 2nd-49th harmonic current value
IAHDV50	4694	R	2	Float32	A	Phase L1 current: 50th harmonic current value
IBHDV50	4696	R	2	Float32	A	Phase L2 current: 50th harmonic current value
ICHDV50	4698	R	2	Float32	A	Phase L3 current: 50th harmonic current value
Percentage of voltage harmonics						
UATHD	5000	R	2	Float32	%	Phase L1 voltage: Percentage of total harmonic
UBTHD	5002	R	2	Float32	%	Phase L2 voltage: Percentage of total harmonic
UCTHD	5004	R	2	Float32	%	Phase L3 voltage: Percentage of total harmonic
UATOHD	5006	R	2	Float32	%	Phase L1 voltage: Odd total harmonic percentage
UBTOHD	5008	R	2	Float32	%	Phase L2 voltage: Odd total harmonic percentage
UCTOHD	5010	R	2	Float32	%	Phase L3 voltage: Odd total harmonic percentage
UATEHD	5012	R	2	Float32	%	Phase L1 voltage: Even total harmonic percentage
UBTEHD	5014	R	2	Float32	%	Phase L2 voltage: Even total harmonic percentage
UCTEHD	5016	R	2	Float32	%	Phase L3 voltage: Even total harmonic percentage
UAHD1	5018	R	2	Float32	%	Phase L1 voltage: 1st harmonic percentage
UBHD1	5020	R	2	Float32	%	Phase L2 voltage: 1st harmonic percentage
UCHD1	5022	R	2	Float32	%	Phase L3 voltage: 1st harmonic percentage
...	5024-5311	...	...	...	...	Phase L1L2L3 voltage: 2nd-49th harmonic percentage
UAHD50	5312	R	2	Float32	%	Phase L1 voltage: 50th harmonic percentage
UBHD50	5314	R	2	Float32	%	Phase L2 voltage: 50th harmonic percentage
UCHD50	5316	R	2	Float32	%	Phase L3 voltage: 50th harmonic percentage
Voltage harmonic value						
UAHDV1	5400	R	2	Float32	V	Phase L1 voltage: 1st harmonic voltage value
UBHDV1	5402	R	2	Float32	V	Phase L2 voltage: 1st harmonic voltage value
UCHDV1	5404	R	2	Float32	V	Phase L3 voltage: 1st harmonic voltage value
...	5406-5693	...	...	...	...	Phase L1L2L3 voltage: 2nd-49th harmonic voltage value
UAHDV50	5694	R	2	Float32	V	Phase L1 voltage: 50th harmonic voltage value
UBHDV50	5696	R	2	Float32	V	Phase L2 voltage: 50th harmonic voltage value
UCHDV50	5698	R	2	Float32	V	Phase L3 voltage: 50th harmonic voltage value

# Max and min value

Register name	Register start address(Decimal system)	Operation	Size	Type	Unit	Description
Current Max and min value						
IA Max	6000	R	2	Float32	A	PhaseL1 Maxi current
IB Max	6002	R	2	Float32	A	PhaseL2 Maxi current
IC Max	6004	R	2	Float32	A	PhaseL3 Maxi current
I AVG Max	6006	R	2	Float32	A	Max three-phase average current
IN Max	6008	R	2	Float32	A	Max value of N-phase current
IA Min	6010	R	2	Float32	A	PhaseL1 Min current
IB Min	6012	R	2	Float32	A	PhaseL2 Min current
IC Min	6014	R	2	Float32	A	PhaseL3 Min current
I AVG Min	6016	R	2	Float32	A	Min three-phase average current
IN Min	6018	R	2	Float32	A	Min value of N-phase current
Voltage Max and min value						
UA Max	6020	R	2	Float32	V	Phase UA-UN:Max voltage
UB Max	6022	R	2	Float32	V	Phase UB-UN:Max voltage
UC Max	6024	R	2	Float32	V	Phase UC-UN: Max voltage
Phase U AVG Max	6026	R	2	Float32	V	Max of average phase voltageof three phase
UA Min	6030	R	2	Float32	V	Phase UA-UN: Min Voltage
UB Min	6032	R	2	Float32	V	Phase UB-UN: Min Voltage
UC Min	6034	R	2	Float32	V	Phase UC-UN: Min Voltage
U AVG Min	6036	R	2	Float32	V	Minof average phase voltageof three phase
U AB Max	6040	R	2	Float32	V	UA-UBMax line voltage
U BC Max	6042	R	2	Float32	V	UB-UCMax line voltage
U CA Max	6044	R	2	Float32	V	UC-UAMax line voltage
LineU AVG Max	6046	R	2	Float32	V	Maximum of average line voltageof three phase
U AB Min	6050	R	2	Float32	V	UA-UBMin Line voltage
U BC Min	6052	R	2	Float32	V	UB-UCMin Line voltage
U CA Min	6054	R	2	Float32	V	UC-UAMin Line voltage
LineU AVG Min	6056	R	2	Float32	V	Min of average line voltageof three phase
Max/min active power						
PA Max	6060	R	2	Float32	kW	Phase L1 Max active power
PB Max	6062	R	2	Float32	kW	PhaseL2 Max active power
PC Max	6064	R	2	Float32	kW	PhaseL3 Max active power
PSUMMax	6066	R	2	Float32	kW	Max three-phase total active power
PA Min	6070	R	2	Float32	kW	PhaseL1 Min active power
PB Min	6072	R	2	Float32	kW	PhaseL2 Min active power
PC Min	6074	R	2	Float32	kW	PhaseL3 Min active power
PSUMMin	6076	R	2	Float32	kW	Min value of three-phase total active power
Max/min reactive power						
QA Max	6080	R	2	Float32	kVar	PhaseL1 Max reactive power
QB Max	6082	R	2	Float32	kVar	PhaseL2 Max reactive power
QC Max	6084	R	2	Float32	kVar	PhaseL3 Max reactive power
QSUMMax	6086	R	2	Float32	kVar	Max three-phase total reactive power
QA Min	6090	R	2	Float32	kVar	PhaseL1 Min reactive power
QB Min	6092	R	2	Float32	kVar	PhaseL2 Min reactive power
QC Min	6094	R	2	Float32	kVar	PhaseL3 Min reactive power
QSUMMin	6096	R	2	Float32	kVar	Min value of three-phase total reactive power
Max/min apparent power						
SA Max	6100	R	2	Float32	kVa	PhaseL1 Max apparent power
SB Max	6102	R	2	Float32	kVa	PhaseL2 Max apparent power
SC Max	6104	R	2	Float32	kVa	PhaseL3 Max apparent power
SSUMMax	6106	R	2	Float32	kVa	Max three-phase total apparent power
SA Min	6110	R	2	Float32	kVa	PhaseL1 Min apparent power
SB Min	6112	R	2	Float32	kVa	PhaseL2 Min apparent power
SC Min	6114	R	2	Float32	kVa	PhaseL3 Min apparent power
SSUMMin	6116	R	2	Float32	kVa	Min value of three-phase total apparent power

# Modbus Register List

## Unbalance

Register name	Register start address (Decimal system)	Operation	Size	Type	Unit	Description
Voltage negative sequence unbalance	7000	R	2	Float32	%	Voltage negative sequence unbalance
Voltage zero-sequence unbalance	7002	R	2	Float32	%	Voltage zero-sequence unbalance
Current negative sequence unbalance	7004	R	2	Float32	%	Current negative sequence unbalance
Current zero-sequence unbalance	7006	R	2	Float32	%	Current zero-sequence unbalance

## Current K factor

Register name	Register start address (Decimal system)	Operation	Size	Type	Unit	Description
KFIA	8000	R	2	Float32	-	PhaseL1 Current K factor
KFIB	8002	R	2	Float32	-	PhaseL2 Current K factor
KFIC	8004	R	2	Float32	-	PhaseL3 Current K factor

## Voltage and current angle

Register name	Register start address (Decimal system)	Operation	Size	Type	Unit	Description
<b>Voltage angle:</b>						
UA	8100	R	2	Float32	°	PhaseL1 Voltage angle
UB	8102	R	2	Float32	°	PhaseL2 Voltage angle
UC	8104	R	2	Float32	°	PhaseL3 Voltage angle
<b>Current angle:</b>						
IA	8106	R	2	Float32	°	PhaseL1 Current angle
IB	8108	R	2	Float32	°	Phase L2 Current angle
IC	8110	R	2	Float32	°	PhaseL3 Current angle
<b>Angle between voltage and current:</b>						
UIA	8112	R	2	Float32	°	PhaseL1 Angle between voltage and current
UIB	8114	R	2	Float32	°	PhaseL2 Angle between voltage and current
UIC	8116	R	2	Float32	°	PhaseL3 Angle between voltage and current

# MEATROL<sup>®</sup> ELECTRICAL

ROGOWSKI TECHNOLOGY (SHANGHAI) CO., LTD

TEL: +86 21 64850006

MOB: 18621563567

EAMIL: info@meatrol.cn

WEBSITE: www.rogowski.cn

